

LASERLOCK CATALOG

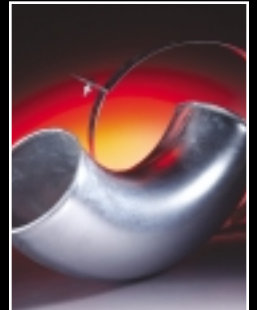

MODULAR DUCTING SYSTEMS





LASER WELDED CLAMP TOGETHER
DUCTING FOR ALL APPLICATIONS, FROM
LIGHT TO HEAVY GAGE DUCT OR
MODERATE TO SEVERE PROCESS CRITERIA.

Quality and Service

Duct Incorporated is an employee-owned business based on the philosophy that quality products and excellent customer service are the highest priority goals for a manufacturing and distribution company. These goals are best achieved in pleasant, friendly surroundings by employees who are valued and respected individuals.

Our dedicated staff of professionals — engineering, customer service personnel and a well-trained, committed work force — offer unmatched experience and depth of capabilities. With over 300 man-years of experience in the manufacture and supply of uncompromised duct quality, Duct Incorporated is the single source for all of your ducting needs.

Worldwide Ducting Supply

Duct Incorporated welcomes export opportunities to countries worldwide. Our products are used in thousands of industrial applications. We point with pride to our approval by prime contractors to supply defense and military applications.

Laser Welded Clamp Together Ducting

Whether your application calls for light to heavy gage duct, or moderate to severe process criteria, **LaserLock™** ducting makes the right product for you. **LaserLock™** ducting is a modular ducting system available in a range of standard sizes in laser welded five foot lengths. The system is complete with bends, blast gate dampers, reducing cones, branch pieces — all joined with lock rings (clamps). The use of lock rings creates a sealed joint and reduces installation time to almost half that of conventional methods of ducting. Our experienced staff can review our capabilities with you, or you can send your specifications to us and we will provide solutions for easy installation and secure clamping of your system.

Duct Size and Options

Using CNC technology and specific tooling designed to cost-effectively produce our product, Duct Incorporated is able to supply ducting from 3" to 80"+ in galvanized, galvaneal (for paint and powder coating), SS (304 and 316) and aluminum. Heavy gage pipe can be either rolled and welded or produced as spiral.

Our welders are certified for military applications and will meet all of your requirements.

Fully welded, buffed or electro-polished product can be made to your specifications with high strength clamping systems. Our ducting from 14 gage to 22 gage has a rolled end directly on the product. There are no "added collars" as typically seen with lesser manufacturing capabilities.

Industries that use our ducting are:

Air Movement

- Air Conditioning
- Air Compressor Heat Recovery
- Commercial Kitchen Cooking
- Exhaust Flues
- Oil & Gas Industry
- Education — Schools & Colleges
- Fume Extraction
- Fumes
- Heat Recovery
- Marine Applications
- Plating & Anodizing

Materials Handling

- Agricultural
- Dust Control
- Grain Handling
- Manufacturing
- Pneumatic Conveying
- Paper
- Packaging
- Mining & Mineral Processing
- Cement Processes
- Fertilizer Manufacturing
- Foodstuff Manufacturing
- Plastics Manufacturing
- Pharmaceutical Production
- Textiles
- Timber Industry

Miscellaneous Applications

- Concrete Forms
- Gravity Chutes
- Original Equipment Applications



877•BUY•DUCT

 **PIPE**
PAGE 1-2

 **ELBOWS**
PAGE 3-5

 **ADAPTERS**
PAGE 6-7

 **BRANCHES**
PAGE 8-10

 **CAPS**
PAGE 11

 **REDUCERS**
PAGE 11

 **SLIDE GATES**
PAGE 12-13

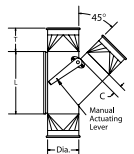
 **DIVERTERS**
PAGE 14

 **CUSTOM HOODS**
PAGE 15

 **TRANSITIONS**
PAGE 16

 **SUCTION HOODS**
PAGE 17

 **HOSES**
PAGE 18-19

 **VALVES**
PAGE 20

 **CLAMPS**
PAGE 2, 19

 **HANGERS**
PAGE 24

 **ACCESSORIES**
PAGE 21-25

ABRASION RESISTANT HOSE	.18
ADAPTER	.6
ANGLE RING FLANGE	.23
AUTOMATIC DIVERTER	.14
AUTOMATIC SLIDE GATE	.13
BALL JOINT	.22
BEAM CLAMP	.25
BELL MOUTH ADAPTER	.7
BIRD SCREEN	.11
BLEED-IN VALVE	.21
BRANCH	.8
BUTTERFLY VALVE	.20
CABLE PIPE HANGER	.24
CLAMP	.2
CUSTOM MANIFOLDS	.15
CUSTOM SUCTION HOODS	.15
CUT-IN	.10
DOUBLE BRANCH	.9
ELBOW	.3
END CAP	.11
FDA HOSE	.18
FLANGE ADAPTER	.6
FLANGED ELBOW	.4
FLANGED PIPE	.1
FLANGED TUBE ELBOW	.4
FLEXIBLE STEEL HOSE	.19
FLOOR SWEEP	.17
HOSE ADAPTERS	.7
HOSE CLAMP	.19
IN-LINE BACK BLAST DAMPER	.20
INSTALLATION TIPS	.30
INSTALLING A SLIP JOINT	.29
MANUAL DIVERTER	.14
MANUAL SEALED SLIDE GATE	.12
MANUAL SLIDE GATE	.12
NO-LOSS STACK HEAD	.22
O-RING	.2
PIPE	.1
PIPE BRACING	.25
PIPE HANGER	.24
RADIAL ARM SAW HOOD	.17
REDUCER	.11
RICOCHET ELBOW	.5
RIGID STEEL HOSE	.19
ROUTER HOOD	.17
SIGHT GLASS	.22
SIZING A PIPE SYSTEM	.31
SLIP JOINT	.2
STANDARD HOSE	.18
T-BRANCH	.9
TAP-IN	.10
TECHNICAL INFORMATION	.27-28
TERMS	.26
THREADED ROD	.25
TR PIPE HANGER	.24
TRANSITIONS	.16
TUBE ELBOW	.3
TUNGSTEN CARBIDE ELBOW	.5
VIBRATION ISOLATOR	.21
Y-BRANCH	.8

PIPE FLANGED PIPE

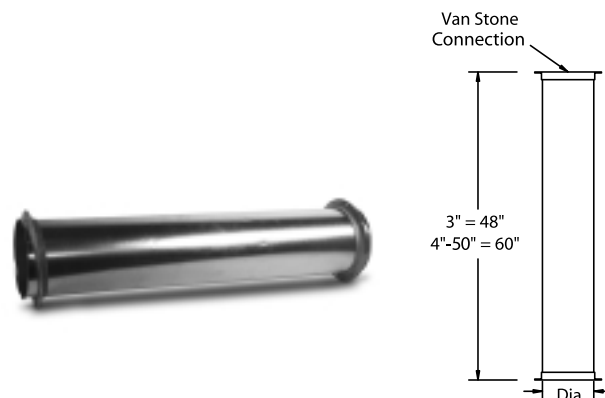
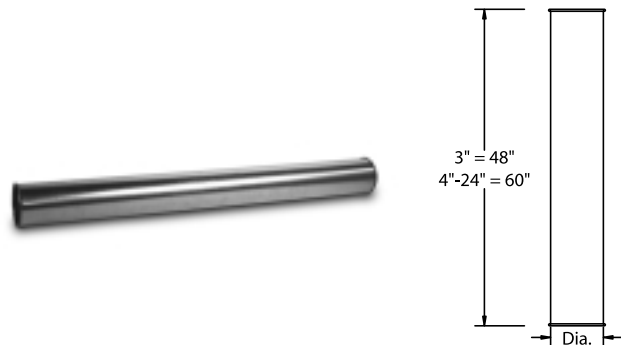

STYLE 110 — PIPE

STYLE 111 — FLANGED PIPE

Diameter Inches	Part Number	Gage Standard	Gage Upgrade Up To
3	11003-0000-xyy00	24	18
4	11004-0000-xyy00	22	18
5	11005-0000-xyy00	22	18
6	11006-0000-xyy00	22	18
7	11007-0000-xyy00	22	18
8	11008-0000-xyy00	22	16
9	11009-0000-xyy00	22	16
10	11010-0000-xyy00	22	16
11	11011-0000-xyy00	22	16
12	11012-0000-xyy00	22	16
13	11013-0000-xyy00	22	16
14	11014-0000-xyy00	20	16
15	11015-0000-xyy00	20	16
16	11016-0000-xyy00	20	16
17	11017-0000-xyy00	20	16
18	11018-0000-xyy00	18	14
20	11020-0000-xyy00	18	14
22	11022-0000-xyy00	18	14
24	11024-0000-xyy00	18	14

Diameter Inches	Part Number	Gage Standard	Gage Upgrade Up To
3	11103-0000-xyy00	24	18
4	11104-0000-xyy00	22	18
5	11105-0000-xyy00	22	18
6	11106-0000-xyy00	22	18
7	11107-0000-xyy00	22	18
8	11108-0000-xyy00	22	16
9	11109-0000-xyy00	22	16
10	11110-0000-xyy00	22	16
11	11111-0000-xyy00	22	16
12	11112-0000-xyy00	22	16
13	11113-0000-xyy00	22	16
14	11114-0000-xyy00	20	16
15	11115-0000-xyy00	20	16
16	11116-0000-xyy00	20	16
17	11117-0000-xyy00	20	16
18	11118-0000-xyy00	18	14
20	11120-0000-xyy00	18	14
22	11122-0000-xyy00	18	14
24	11124-0000-xyy00	18	14
26	11126-0000-xyy00	18	14
28	11128-0000-xyy00	18	14
30	11130-0000-xyy00	18	14
32	11132-0000-xyy00	18	14
34	11134-0000-xyy00	18	14
36	11136-0000-xyy00	18	14
38	11138-0000-xyy00	18	14
40	11140-0000-xyy00	18	14
42	11142-0000-xyy00	16	14
44	11144-0000-xyy00	16	14
46	11146-0000-xyy00	16	14
48	11148-0000-xyy00	16	14
50	11150-0000-xyy00	16	14

Pipe is constructed in various materials with a welded longitudinal seam. Pipe is approximately 5' in length with rolled ends for an easy clamp together installation. (3" is approximately 4' in length)

Flanged Pipe is constructed in various materials with a welded longitudinal seam. Pipe is approximately 5' or 10' (center seamed) in length. Larger diameters available. Please call for availability.

x = material 1 – galvanized 2 – galvaneal
3 – black metal 4 – 304ss 5 – 316ss
yy = gage

x = material 1 – galvanized 2 – galvaneal
3 – black metal 4 – 304ss 5 – 316ss
yy = gage

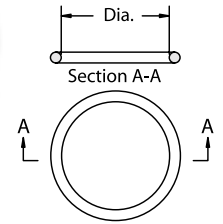
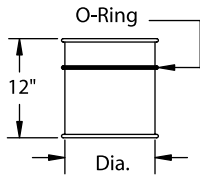

STYLE 119 — SLIP JOINT

STYLE 120 — CLAMP

Diameter Inches	Part Number	Gage Standard	Gage Upgrade Up To
3	11903-0000-xyy00	24	18
4	11904-0000-xyy00	22	18
5	11905-0000-xyy00	22	18
6	11906-0000-xyy00	22	18
7	11907-0000-xyy00	22	18
8	11908-0000-xyy00	22	16
9	11909-0000-xyy00	22	16
10	11910-0000-xyy00	22	16
11	11911-0000-xyy00	22	16
12	11912-0000-xyy00	22	16
13	11913-0000-xyy00	22	16
14	11914-0000-xyy00	20	16
15	11915-0000-xyy00	20	16
16	11916-0000-xyy00	20	16
17	11917-0000-xyy00	20	16
18	11918-0000-xyy00	18	14
20	11920-0000-xyy00	18	14
22	11922-0000-xyy00	18	14
24	11924-0000-xyy00	18	14

Diameter Inches	Part Number
3	12003-0000-x000z
4	12004-0000-x000z
5	12005-0000-x000z
6	12006-0000-x000z
7	12007-0000-x000z
8	12008-0000-x000z
9	12009-0000-x000z
10	12010-0000-x000z
11	12011-0000-x000z
12	12012-0000-x000z
13	12013-0000-x000z
14	12014-0000-x000z
15	12015-0000-x000z
16	12016-0000-x000z
17	12017-0000-x000z
18	12018-0000-x000z
20	12020-0000-x000z
22	12022-0000-x000z
24	12024-0000-x000z

Diameter Inches	Part Number
3	12403-0000-0000z
4	12404-0000-0000z
5	12405-0000-0000z
6	12406-0000-0000z
7	12407-0000-0000z
8	12408-0000-0000z
9	12409-0000-0000z
10	12410-0000-0000z
11	12411-0000-0000z
12	12412-0000-0000z
13	12413-0000-0000z
14	12414-0000-0000z
15	12415-0000-0000z
16	12416-0000-0000z
17	12417-0000-0000z
18	12418-0000-0000z
20	12420-0000-0000z
22	12422-0000-0000z
24	12424-0000-0000z

The Slip Joint is constructed in various materials with a welded longitudinal seam. Approximately 12" in length with a rubber o-ring. It is used in conjunction with our **LaserLock™** Pipe to form an adjustable length of pipe. Alternative o-rings are available.

Clamps are constructed in various materials and come complete with locking pin. Gasket material surrounds inside of clamp for secure connection. Alternative seals are available.

O-Rings are constructed in black rubber and high temperature red silicone materials for secure connection.

x = material 1 – galvanized 2 – galvaneal
3 – black metal 4 – 304ss 5 – 316ss
yy = gage

x = material 1 – galvanized 2 – galvaneal
3 – black metal 4 – 304ss 5 – 316ss
z = gasket material 0 – high density foam
1 – teflon/FDA 3 – no gasket

z = o-ring material
0 – black rubber 2 – red silicone

ELBOWS

TUBE ELBOWS

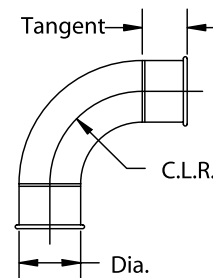
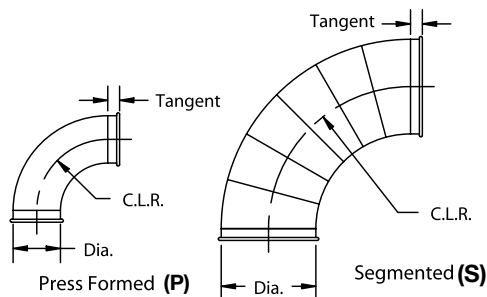

STYLE 130 — ELBOWS

STYLE 132 — TUBE ELBOWS

Diameter Inches	Part Number	Construction Method		CLR Standard	Gage Standard	Gage Upgrade Up To	Tangent
		STD	Other				
3	13003-ddcc-xyy00	P	S	1.5	24	18	1
4	13004-ddcc-xyy00	P	S	1.5	24	16	1
5	13005-ddcc-xyy00	P	S	1.5	24	16	1
6	13006-ddcc-xyy00	P	S	1.5	24	16	1
7	13007-ddcc-xyy00	P	S	1.5	24	16	1
8	13008-ddcc-xyy00	P	S	1.5	24	16	1
9	13009-ddcc-xyy00	P	S	1.5	22	16	1
10	13010-ddcc-xyy00	P	S	1.5	22	16	1
11	13011-ddcc-xyy00	P	S	1.5	22	16	1
12	13012-ddcc-xyy00	P	S	1.5	22	16	1
13	13013-ddcc-xyy00	S	S	1.5	20	14	1
14	13014-ddcc-xyy00	S	S	1.5	20	14	1
15	13015-ddcc-xyy00	S	S	1.5	20	14	1
16	13016-ddcc-xyy00	S	S	1.5	20	14	1
17	13017-ddcc-xyy00	S	S	1.5	20	14	1
18	13018-ddcc-xyy00	S	S	1.5	18	14	1
20	13020-ddcc-xyy00	S	S	1.5	18	14	1
22	13022-ddcc-xyy00	S	S	1.5	18	14	1
24	13024-ddcc-xyy00	S	S	1.5	18	14	1

Diameter Inches	Part Number	CLR Std.	CLR Avail.		
			Up To	Gage	Tangent
4	13204-ddcc-x1400	1.5	12.0	14	3.750
5	13205-ddcc-x1400	1.5	9.6	14	4.375
6	13206-ddcc-x1400	1.5	10.0	14	4.375
8	13208-ddcc-x1200	1.5	6.0	12	4.875
10	13210-ddcc-x1200	3.2	4.8	12	4.875

All collars will be made in 16 gage material.

Any modification from standard construction will be manufactured as segmented.
 Elbows heavier than 18 gage material will be manufactured with lapped and welded seams.
 Larger CLR is available in segmented construction.

x = material 1 – galvanized 2 – galvaneal 3 – black metal 4 – 304ss 5 – 316ss
yy = gage
dd = degree 90 = 90 degree 60 = 60 degree 45 = 45 degree 30 = 30 degree 15 = 15 degree
cc = CLR 15 = 1.5 CLR 25 = 2.5 CLR

x = material 1 – galvanized
 3 – black metal 4 – 304ss 5 – 316ss
dd = degree 90 = 90 degree 60 = 60 degree
 45 = 45 degree 30 = 30 degree 15 = 15 degree
cc = CLR 15 = 1.5 CLR 25 = 2.5 CLR

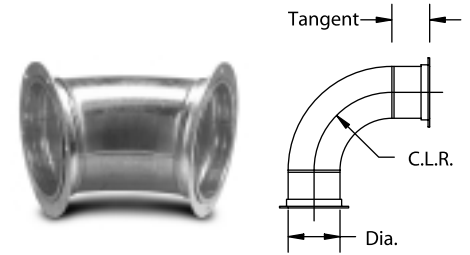
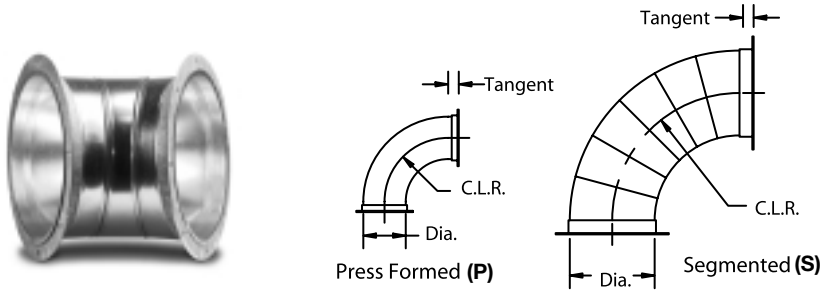

STYLE 134 — FLANGED ELBOWS

STYLE 135 — FLANGED TUBE ELBOWS

Diameter Inches	Part Number	Construction Method		CLR Standard	Gage Standard	Gage Upgrade Up To	Tangent
		STD	Other				
3	13403-ddcc-xyy00	P	S	1.5	24	18	1.5
4	13404-ddcc-xyy00	P	S	1.5	24	16	1.5
5	13405-ddcc-xyy00	P	S	1.5	24	16	1.5
6	13406-ddcc-xyy00	P	S	1.5	24	16	1.5
7	13407-ddcc-xyy00	P	S	1.5	24	16	1.5
8	13408-ddcc-xyy00	P	S	1.5	24	16	2.0
9	13409-ddcc-xyy00	P	S	1.5	22	16	2.0
10	13410-ddcc-xyy00	P	S	1.5	22	16	2.0
11	13411-ddcc-xyy00	P	S	1.5	22	16	2.0
12	13412-ddcc-xyy00	P	S	1.5	22	16	2.0
13	13413-ddcc-xyy00	S	S	1.5	20	14	2.0
14	13414-ddcc-xyy00	S	S	1.5	20	14	2.0
15	13415-ddcc-xyy00	S	S	1.5	20	14	2.0
16	13416-ddcc-xyy00	S	S	1.5	20	14	2.0
17	13417-ddcc-xyy00	S	S	1.5	20	14	2.0
18	13418-ddcc-xyy00	S	S	1.5	18	14	2.0
20	13420-ddcc-xyy00	S	S	1.5	18	14	2.0
22	13422-ddcc-xyy00	S	S	1.5	18	14	2.0
24	13424-ddcc-xyy00	S	S	1.5	18	14	2.0
26	13426-ddcc-xyy00	S	S	1.5	18	14	2.0
28	13428-ddcc-xyy00	S	S	1.5	18	14	2.0
30	13430-ddcc-xyy00	S	S	1.5	18	14	2.0
32	13432-ddcc-xyy00	S	S	1.5	18	14	2.0
34	13434-ddcc-xyy00	S	S	1.5	18	14	2.0
36	13436-ddcc-xyy00	S	S	1.5	18	14	2.0
38	13438-ddcc-xyy00	S	S	1.5	18	14	2.0
40	13440-ddcc-xyy00	S	S	1.5	18	14	2.0
42	13442-ddcc-xyy00	S	S	1.5	16	14	2.0
44	13444-ddcc-xyy00	S	S	1.5	16	14	2.0
46	13446-ddcc-xyy00	S	S	1.5	16	14	2.0
48	13448-ddcc-xyy00	S	S	1.5	16	14	2.0
50	13450-ddcc-xyy00	S	S	1.5	16	14	2.0

Diameter Inches	Part Number	CLR Std.	CLR Avail. Up to	Gage Std.	Tangent
5	13505-ddcc-x1400	1.5	9.6	14	4.375
6	13506-ddcc-x1400	1.5	10.0	14	4.375
8	13508-ddcc-x1200	1.5	6.0	12	4.875
10	13510-ddcc-x1200	3.2	4.8	12	4.875

All collars will be made in 16 gage material.

Larger diameters available. Please call for availability.
Elbows heavier than 18 gage material will be manufactured with lapped and welded seams.
Larger CLR is available in segmented construction.

x = material 1 – galvanized 2 – galvanneal 3 – black metal 4 – 304ss 5 – 316ss
yy = gage
dd = degree 90 = 90 degree 60 = 60 degree 45 = 45 degree 30 = 30 degree 15 = 15 degree
cc = CLR 15 = 1.5 CLR 25 = 2.5 CLR

x = material 1 – galvanized 3 – black metal 4 – 304ss 5 – 316ss
dd = degree 90 = 90 degree 60 = 60 degree 45 = 45 degree 30 = 30 degree 15 = 15 degree
cc = CLR 15 = 1.5 CLR 25 = 2.5 CLR

RICOCHET ELBOW TUNGSTEN CARBIDE COATED ELBOW



STYLE 133 — RICOCHET™ ELBOW

Diameter Inches	Part Number	CLR Standard
6	13306-9010-00000	1.0

Abrasive-Resistant Elbows

LaserLock™ presents the Ricochet™ Elbow. This elbow is constructed totally of a polyurethane polymer — not just a liner. The Ricochet™ elbow will greatly increase the resistance to abrasive materials. The ‘bouncing’ effect of the polymer reduces wear and tear that leads to the deterioration of many other types of elbows — such as rubber-coated, cast iron and even ceramic — by as much as 10 to 1. The elbow is also FDA approved. It can be ordered with raw, flanged or **LaserLock™** clamp-together ends. This is the perfect component to handle very abrasive products such as sand, glass bead, grit, fiberglass and cement dust. The exterior handle and mounting flange allow for ease of installation and mounting in the system. The abrasive resistance of this elbow allows the total system to be constructed of lighter gages in the straight runs, which gives you a system that will last much longer than heavier gages at less cost.

The elbows are currently available in 6" 90 degree. Call for availability of other sizes and degrees.



STYLE 136 —
TUNGSTEN CARBIDE COATED ELBOW

Diameter Inches	Part Number	CLR Standard	Gage Standard
4	13604-ddcc-xyy00	1.5	24
5	13605-ddcc-xyy00	1.5	24
6	13606-ddcc-xyy00	1.5	24
7	13607-ddcc-xyy00	1.5	24
8	13608-ddcc-xyy00	1.5	24
9	13609-ddcc-xyy00	1.5	22
10	13610-ddcc-xyy00	1.5	22
11	13611-ddcc-xyy00	1.5	22
12	13612-ddcc-xyy00	1.5	22
13	13613-ddcc-xyy00	1.5	20
14	13614-ddcc-xyy00	1.5	20

Tungsten Carbide Coated Elbows

- Flame-spray coating applied to standard **LaserLock™** or flanged elbows and fittings.
- Hard surface greatly increases life of elbows and fittings.
- Can be applied to large diameters.
- Reduces equipment downtime.
- Can be incorporated in light gage systems.
- Applications include metal dusts, automotive brake dust, fiberglass and fertilizer dust.
- Available in other fittings as well. Call for more information.

x = material 1 – galvanized 2 – galvaneal
3 – black metal 4 – 304ss 5 – 316ss
yy = gage

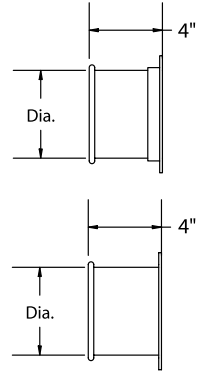
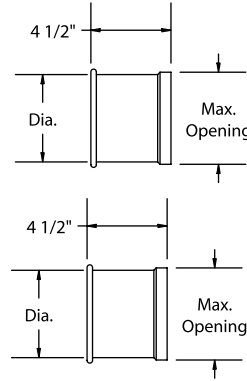

STYLE 140 — RAW/EXPANDED ADAPTER

STYLE 144 — FLANGE ADAPTER

Diameter Inches	Part Number	Raw End ID	Raw End OD	Gage Standard	Gage Upgrade Up To	Length	Max Opening ID
3	14003-0000-xyy00	2.80	2.90	24	18	4.5	3.125
4	14004-0000-xyy00	3.80	3.90	22	18	4.5	4.125
5	14005-0000-xyy00	4.80	4.90	22	18	4.5	5.125
6	14006-0000-xyy00	5.80	5.90	22	18	4.5	6.125
7	14007-0000-xyy00	6.80	6.90	22	18	4.5	7.125
8	14008-0000-xyy00	7.80	7.90	22	16	4.5	8.125
9	14009-0000-xyy00	8.80	8.90	22	16	4.5	9.125
10	14010-0000-xyy00	9.90	10.00	22	16	4.5	10.125
11	14011-0000-xyy00	10.90	11.00	22	16	4.5	11.125
12	14012-0000-xyy00	11.90	12.06	22	16	4.5	12.200
13	14013-0000-xyy00	12.90	13.06	22	16	4.5	13.200
14	14014-0000-xyy00	13.90	14.06	20	16	4.5	14.200
15	14015-0000-xyy00	14.90	15.06	20	16	4.5	15.200
16	14016-0000-xyy00	15.90	16.06	20	16	4.5	16.200
17	14017-0000-xyy00	16.90	17.06	20	16	4.5	17.200
18	14018-0000-xyy00	17.87	18.00	18	14	4.5	18.200
20	14020-0000-xyy00	19.87	20.00	18	14	4.5	20.200
22	14022-0000-xyy00	21.87	22.06	18	14	4.5	22.250
24	14024-0000-xyy00	23.87	24.06	18	14	4.5	24.250

Diameter Inches	Part Number	Gage Std.	Gage Upgrade Up To	Length
3	14403-0000-xyy0f	24	18	4
4	14404-0000-xyy0f	22	18	4
5	14405-0000-xyy0f	22	18	4
6	14406-0000-xyy0f	22	18	4
7	14407-0000-xyy0f	22	18	4
8	14408-0000-xyy0f	22	16	4
9	14409-0000-xyy0f	22	16	4
10	14410-0000-xyy0f	22	16	4
11	14411-0000-xyy0f	22	16	4
12	14412-0000-xyy0f	22	16	4
13	14413-0000-xyy0f	22	16	4
14	14414-0000-xyy0f	20	16	4
15	14415-0000-xyy0f	20	16	4
16	14416-0000-xyy0f	20	16	4
17	14417-0000-xyy0f	20	16	4
18	14418-0000-xyy0f	18	14	4
20	14420-0000-xyy0f	18	14	4
22	14422-0000-xyy0f	18	14	4
24	14424-0000-xyy0f	18	14	4

Opening diameter must be specified on expanded adapters.

Flat flange blank if hole pattern is not provided.

x = material 1 – galvanized 2 – galvaneal 3 – black metal 4 – 304ss 5 – 316ss
yy = gage

x = material 1 – galvanized 2 – galvaneal
3 – black metal 4 – 304ss 5 – 316ss
yy = gage
f = flange type 1 – angle flange
2 – flat flange – please specify hole pattern

**HOSE ADAPTER
BELL MOUTH ADAPTER**

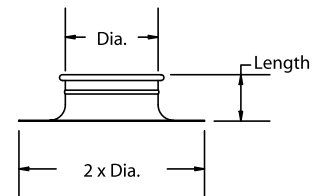
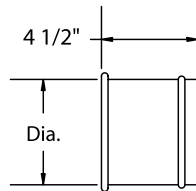

STYLE 142 — HOSE ADAPTER

STYLE 143 — BELL MOUTH ADAPTER

Diameter Inches	Part Number	Gage Standard	Gage Upgrade Up To	Length
3	14203-0000-xyy00	24	18	4.5
4	14204-0000-xyy00	22	18	4.5
5	14205-0000-xyy00	22	18	4.5
6	14206-0000-xyy00	22	18	4.5
7	14207-0000-xyy00	22	18	4.5
8	14208-0000-xyy00	22	16	4.5
9	14209-0000-xyy00	22	16	4.5
10	14210-0000-xyy00	22	16	4.5
11	14211-0000-xyy00	22	16	4.5
12	14212-0000-xyy00	22	16	4.5
13	14213-0000-xyy00	22	16	4.5
14	14214-0000-xyy00	20	16	4.5
15	14215-0000-xyy00	20	16	4.5
16	14216-0000-xyy00	20	16	4.5
17	14217-0000-xyy00	20	16	4.5
18	14218-0000-xyy00	18	14	4.5
20	14220-0000-xyy00	18	14	4.5
22	14222-0000-xyy00	18	14	4.5
24	14224-0000-xyy00	18	14	4.5

Diameter Inches	Part Number	Gage Standard
3	14303-0000-xyy00	16
4	14304-0000-xyy00	16
5	14305-0000-xyy00	16
6	14306-0000-xyy00	16
7	14307-0000-xyy00	16
8	14308-0000-xyy00	16
9	14309-0000-xyy00	16
10	14310-0000-xyy00	16
11	14311-0000-xyy00	16
12	14312-0000-xyy00	16
13	14313-0000-xyy00	16
14	14314-0000-xyy00	16
15	14315-0000-xyy00	16
16	14316-0000-xyy00	16
17	14317-0000-xyy00	16
18	14318-0000-xyy00	16
20	14320-0000-xyy00	16
22	14322-0000-xyy00	16
24	14324-0000-xyy00	16

x = material 1 – galvanized 2 – galvaneal
3 – black metal 4 – 304ss 5 – 316ss
yy = gage

x = material 1 – galvanized 2 – galvaneal
3 – black metal 4 – 304ss 5 – 316ss
yy = gage

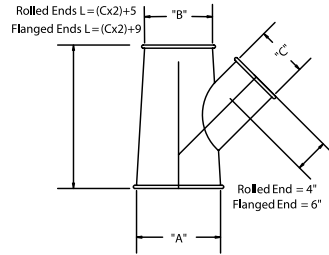

45° Standard

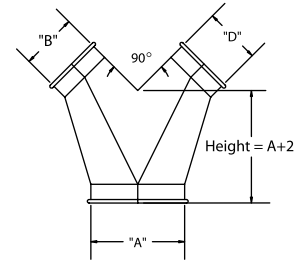

90° Standard

STYLE 150 — BRANCH

STYLE 151 — Y-BRANCH

Diameter Inches	Part Number	Gage Standard	Gage Upgrade Up To
3	15003-dd00-xyy00	22	18
4	15004-dd00-xyy00	22	18
5	15005-dd00-xyy00	22	18
6	15006-dd00-xyy00	22	18
7	15007-dd00-xyy00	22	18
8	15008-dd00-xyy00	22	16
9	15009-dd00-xyy00	22	16
10	15010-dd00-xyy00	22	16
11	15011-dd00-xyy00	22	16
12	15012-dd00-xyy00	22	16
13	15013-dd00-xyy00	20	16
14	15014-dd00-xyy00	20	16
15	15015-dd00-xyy00	20	16
16	15016-dd00-xyy00	20	16
17	15017-dd00-xyy00	20	16
18	15018-dd00-xyy00	18	14
20	15020-dd00-xyy00	18	14
22	15022-dd00-xyy00	18	14
24	15024-dd00-xyy00	18	14
26	15026-dd00-xyy00	18	14
28	15028-dd00-xyy00	18	14
30	15030-dd00-xyy00	18	14
32	15032-dd00-xyy00	18	14
34	15034-dd00-xyy00	18	14
36	15036-dd00-xyy00	18	14
38	15038-dd00-xyy00	18	14
40	15040-dd00-xyy00	18	14
42	15042-dd00-xyy00	18	14
44	15044-dd00-xyy00	18	14
46	15046-dd00-xyy00	18	14
48	15048-dd00-xyy00	18	14
50	15050-dd00-xyy00	18	14

Diameter Inches	Part Number	Gage Standard	Gage Upgrade Up To
3	15103-dd00-xyy00	22	18
4	15104-dd00-xyy00	22	18
5	15105-dd00-xyy00	22	18
6	15106-dd00-xyy00	22	18
7	15107-dd00-xyy00	22	18
8	15108-dd00-xyy00	22	16
9	15109-dd00-xyy00	22	16
10	15110-dd00-xyy00	22	16
11	15111-dd00-xyy00	22	16
12	15112-dd00-xyy00	22	16
13	15113-dd00-xyy00	22	16
14	15114-dd00-xyy00	20	16
15	15115-dd00-xyy00	20	16
16	15116-dd00-xyy00	20	16
17	15117-dd00-xyy00	20	16
18	15118-dd00-xyy00	18	14
20	15120-dd00-xyy00	18	14
22	15122-dd00-xyy00	18	14
24	15124-dd00-xyy00	18	14
26	15126-dd00-xyy00	18	14
28	15128-dd00-xyy00	18	14
30	15130-dd00-xyy00	18	14
32	15132-dd00-xyy00	18	14
34	15134-dd00-xyy00	18	14
36	15136-dd00-xyy00	18	14
38	15138-dd00-xyy00	18	14
40	15140-dd00-xyy00	18	14
42	15142-dd00-xyy00	18	14
44	15144-dd00-xyy00	18	14
46	15146-dd00-xyy00	18	14
48	15148-dd00-xyy00	18	14
50	15150-dd00-xyy00	18	14

Specify A-B-C dimensions when ordering.
Size by "A" dimension.
45° branch is standard. 20° – 90° available.

Specify A-B-D dimensions when ordering.
Size by "A" dimension.
90° branch is standard. 45° – 135° available.

x = material 1 – galvanized 2 – galvaneal
3 – black metal 4 – 304ss 5 – 316ss
yy = gage
dd = degree of branch 30 – 30 degree 45 – 45 degree

x = material 1 – galvanized 2 – galvaneal
3 – black metal 4 – 304ss 5 – 316ss
yy = gage
dd = degree of branch 30 – 30 degree 45 – 45 degree

DOUBLE BRANCH

T-BRANCH

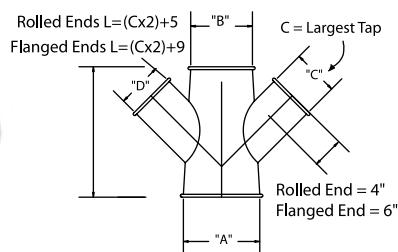

45° Standard

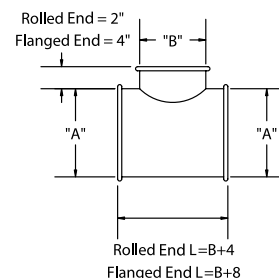

STYLE 152 — DOUBLE BRANCH

STYLE 153 — T-BRANCH

Diameter Inches	Part Number	Gage Standard	Gage Upgrade Up To
3	15203-dd00-xyy00	22	18
4	15204-dd00-xyy00	22	18
5	15205-dd00-xyy00	22	18
6	15206-dd00-xyy00	22	18
7	15207-dd00-xyy00	22	18
8	15208-dd00-xyy00	22	16
9	15209-dd00-xyy00	22	16
10	15210-dd00-xyy00	22	16
11	15211-dd00-xyy00	22	16
12	15212-dd00-xyy00	22	16
13	15213-dd00-xyy00	22	16
14	15214-dd00-xyy00	20	16
15	15215-dd00-xyy00	20	16
16	15216-dd00-xyy00	20	16
17	15217-dd00-xyy00	20	16
18	15218-dd00-xyy00	18	14
20	15220-dd00-xyy00	18	14
22	15222-dd00-xyy00	18	14
24	15224-dd00-xyy00	18	14
26	15226-dd00-xyy00	18	14
28	15228-dd00-xyy00	18	14
30	15230-dd00-xyy00	18	14
32	15232-dd00-xyy00	18	14
34	15234-dd00-xyy00	18	14
36	15236-dd00-xyy00	18	14
38	15238-dd00-xyy00	18	14
40	15240-dd00-xyy00	18	14
42	15242-dd00-xyy00	18	14
44	15244-dd00-xyy00	18	14
46	15246-dd00-xyy00	18	14
48	15248-dd00-xyy00	18	14
50	15250-dd00-xyy00	18	14

Diameter Inches	Part Number	Gage Standard	Gage Upgrade Up To
3	15303-0000-xyy00	22	18
4	15304-0000-xyy00	22	18
5	15305-0000-xyy00	22	18
6	15306-0000-xyy00	22	18
7	15307-0000-xyy00	22	18
8	15308-0000-xyy00	22	16
9	15309-0000-xyy00	22	16
10	15310-0000-xyy00	22	16
11	15311-0000-xyy00	22	16
12	15312-0000-xyy00	22	16
13	15313-0000-xyy00	22	16
14	15314-0000-xyy00	20	16
15	15315-0000-xyy00	20	16
16	15316-0000-xyy00	20	16
17	15317-0000-xyy00	20	16
18	15318-0000-xyy00	18	14
20	15320-0000-xyy00	18	14
22	15322-0000-xyy00	18	14
24	15324-0000-xyy00	18	14
26	15326-0000-xyy00	18	14
28	15328-0000-xyy00	18	14
30	15330-0000-xyy00	18	14
32	15332-0000-xyy00	18	14
34	15334-0000-xyy00	18	14
36	15336-0000-xyy00	18	14
38	15338-0000-xyy00	18	14
40	15340-0000-xyy00	18	14
42	15342-0000-xyy00	18	14
44	15344-0000-xyy00	18	14
46	15346-0000-xyy00	18	14
48	15348-0000-xyy00	18	14
50	15350-0000-xyy00	18	14

Specify A-B-C-D dimensions when ordering.
 Size by "A" dimension.
 20° – 90° available. 45° is standard.

Specify A-B dimensions when ordering.
 Order by "A" dimension.

x = material 1 – galvanized 2 – galvaneal
 3 – black metal 4 – 304ss 5 – 316ss

yy = gage

dd = degree of branch 30 – 30 degree 45 – 45 degree

x = material 1 – galvanized 2 – galvaneal
 3 – black metal 4 – 304ss 5 – 316ss

yy = gage

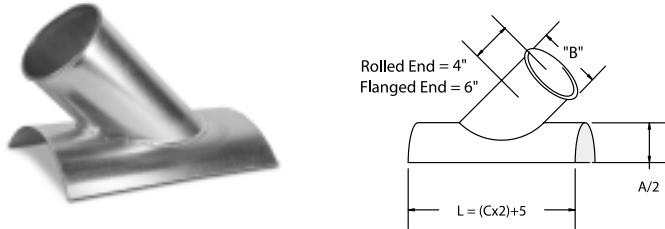

45° Standard

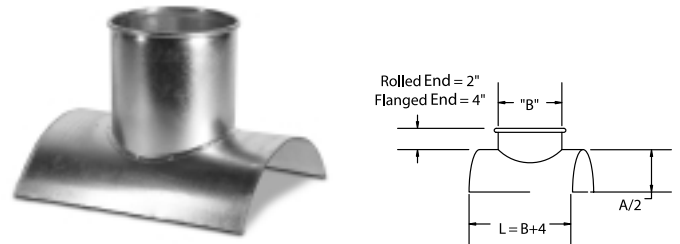

STYLE 154 — CUT-IN

STYLE 155 — TAP-IN

Diameter Inches	Part Number	Gage Standard	Gage Upgrade Up To
3	15403-dd00-xyy00	22	18
4	15404-dd00-xyy00	22	18
5	15405-dd00-xyy00	22	18
6	15406-dd00-xyy00	22	18
7	15407-dd00-xyy00	22	18
8	15408-dd00-xyy00	22	16
9	15409-dd00-xyy00	22	16
10	15410-dd00-xyy00	22	16
11	15411-dd00-xyy00	22	16
12	15412-dd00-xyy00	22	16
13	15413-dd00-xyy00	22	16
14	15414-dd00-xyy00	20	16
15	15415-dd00-xyy00	20	16
16	15416-dd00-xyy00	20	16
17	15417-dd00-xyy00	20	16
18	15418-dd00-xyy00	18	14
20	15420-dd00-xyy00	18	14
22	15422-dd00-xyy00	18	14
24	15424-dd00-xyy00	18	14
26	15426-dd00-xyy00	18	14
28	15428-dd00-xyy00	18	14
30	15430-dd00-xyy00	18	14
32	15432-dd00-xyy00	18	14
34	15434-dd00-xyy00	18	14
36	15436-dd00-xyy00	18	14
38	15438-dd00-xyy00	18	14
40	15440-dd00-xyy00	18	14
42	15442-dd00-xyy00	18	14
44	15444-dd00-xyy00	18	14
46	15446-dd00-xyy00	18	14
48	15448-dd00-xyy00	18	14
50	15450-dd00-xyy00	18	14

Diameter Inches	Part Number	Gage Standard	Gage Upgrade Up To
3	15503-0000-xyy00	22	18
4	15504-0000-xyy00	22	18
5	15505-0000-xyy00	22	18
6	15506-0000-xyy00	22	18
7	15507-0000-xyy00	22	18
8	15508-0000-xyy00	22	16
9	15509-0000-xyy00	22	16
10	15510-0000-xyy00	22	16
11	15511-0000-xyy00	22	16
12	15512-0000-xyy00	22	16
13	15513-0000-xyy00	22	16
14	15514-0000-xyy00	20	16
15	15515-0000-xyy00	20	16
16	15516-0000-xyy00	20	16
17	15517-0000-xyy00	20	16
18	15518-0000-xyy00	18	14
20	15520-0000-xyy00	18	14
22	15522-0000-xyy00	18	14
24	15524-0000-xyy00	18	14
26	15526-0000-xyy00	18	14
28	15528-0000-xyy00	18	14
30	15530-0000-xyy00	18	14
32	15532-0000-xyy00	18	14
34	15534-0000-xyy00	18	14
36	15536-0000-xyy00	18	14
38	15538-0000-xyy00	18	14
40	15540-0000-xyy00	18	14
42	15542-0000-xyy00	18	14
44	15544-0000-xyy00	18	14
46	15546-0000-xyy00	18	14
48	15548-0000-xyy00	18	14
50	15550-0000-xyy00	18	14

Specify A-B dimensions when ordering.
Order by "B" dimension. 45° is standard.

Specify A-B dimensions when ordering.
Order by "B" dimension.

x = material 1 – galvanized 2 – galvaneal
3 – black metal 4 – 304ss 5 – 316ss
yy = gage
dd = degree of branch 30 – 30 degree 45 – 45 degree

x = material 1 – galvanized 2 – galvaneal
3 – black metal 4 – 304ss 5 – 316ss
yy = gage

REDUCER
END CAP
BIRD SCREEN CAP

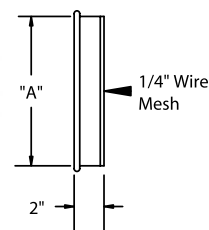
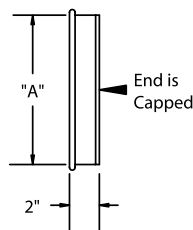
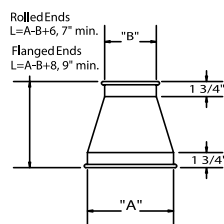

STYLE 158 — REDUCER

STYLE 161 — BIRD SCREEN CAP

Diameter Inches	Part Number	Gage Standard	Gage Upgrade Up To
3	15803-0000-xyy00	22	18
4	15804-0000-xyy00	22	18
5	15805-0000-xyy00	22	18
6	15806-0000-xyy00	22	18
7	15807-0000-xyy00	22	18
8	15808-0000-xyy00	22	16
9	15809-0000-xyy00	22	16
10	15810-0000-xyy00	22	16
11	15811-0000-xyy00	22	16
12	15812-0000-xyy00	22	16
13	15813-0000-xyy00	20	16
14	15814-0000-xyy00	20	16
15	15815-0000-xyy00	20	16
16	15816-0000-xyy00	20	16
17	15817-0000-xyy00	20	16
18	15818-0000-xyy00	18	14
20	15820-0000-xyy00	18	14
22	15822-0000-xyy00	18	14
24	15824-0000-xyy00	18	14
26	15826-0000-xyy00	18	14
28	15828-0000-xyy00	18	14
30	15830-0000-xyy00	18	14
32	15832-0000-xyy00	18	14
34	15834-0000-xyy00	18	14
36	15836-0000-xyy00	18	14
38	15838-0000-xyy00	18	14
40	15840-0000-xyy00	18	14
42	15842-0000-xyy00	18	14
44	15844-0000-xyy00	18	14
46	15846-0000-xyy00	18	14
48	15848-0000-xyy00	18	14
50	15850-0000-xyy00	18	14

Diameter Inches	Part Number	Gage Standard	Gage Upgrade Up To
3	16003-0000-xyy00	24	18
4	16004-0000-xyy00	22	18
5	16005-0000-xyy00	22	18
6	16006-0000-xyy00	22	18
7	16007-0000-xyy00	22	18
8	16008-0000-xyy00	22	16
9	16009-0000-xyy00	22	16
10	16010-0000-xyy00	22	16
11	16011-0000-xyy00	22	16
12	16012-0000-xyy00	22	16
13	16013-0000-xyy00	22	16
14	16014-0000-xyy00	20	16
15	16015-0000-xyy00	20	16
16	16016-0000-xyy00	20	16
17	16017-0000-xyy00	20	16
18	16018-0000-xyy00	18	14
20	16020-0000-xyy00	18	14
22	16022-0000-xyy00	18	14
24	16024-0000-xyy00	18	14

Diameter Inches	Part Number	Gage Standard	Gage Upgrade Up To
3	16103-0000-xyy00	22	18
4	16104-0000-xyy00	22	18
5	16105-0000-xyy00	22	18
6	16106-0000-xyy00	22	18
7	16107-0000-xyy00	22	18
8	16108-0000-xyy00	22	16
9	16109-0000-xyy00	22	16
10	16110-0000-xyy00	22	16
11	16111-0000-xyy00	22	16
12	16112-0000-xyy00	22	16
13	16113-0000-xyy00	22	16
14	16114-0000-xyy00	20	16
15	16115-0000-xyy00	20	16
16	16116-0000-xyy00	20	16
17	16117-0000-xyy00	20	16
18	16118-0000-xyy00	18	14
20	16120-0000-xyy00	18	14
22	16122-0000-xyy00	18	14
24	16124-0000-xyy00	18	14

Specify A-B dimensions when ordering.
Order by "A" dimension.

x = material 1 – galvanized 2 – galvaneal
3 – black metal 4 – 304ss 5 – 316ss
yy = gage

x = material 1 – galvanized 2 – galvaneal
3 – black metal 4 – 304ss 5 – 316ss
yy = gage

x = material 1 – galvanized 2 – galvaneal
3 – black metal 4 – 304ss 5 – 316ss
yy = gage

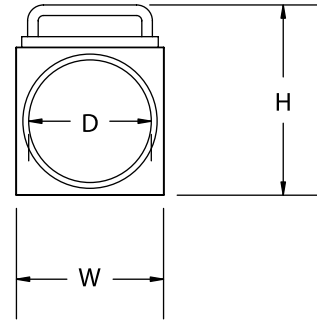
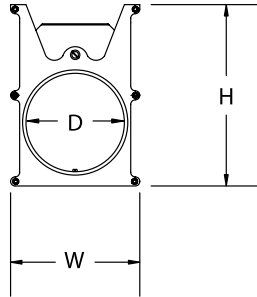

STYLE 170 — MANUAL SLIDE GATE

STYLE 172 — MANUAL SEALED SLIDE GATE

Diameter Inches	Part Number	Gage	Height	Width	Depth
3	17003-0000-xyy00	22	7.00	5.25	5.750
4	17004-0000-xyy00	22	7.00	6.12	5.750
5	17005-0000-xyy00	22	7.00	6.12	5.750
6	17006-0000-xyy00	22	10.00	7.00	5.750
7	17007-0000-xyy00	22	11.25	8.00	5.375
8	17008-0000-xyy00	22	12.00	9.37	5.375
9	17009-0000-xyy00	22	13.25	11.00	5.500
10	17010-0000-xyy00	22	14.37	11.37	5.500
11	17011-0000-xyy00	22	16.25	13.50	5.000
12	17012-0000-xyy00	22	16.25	13.50	5.000
13	17013-0000-xyy00	20	17.87	15.75	5.000
14	17014-0000-xyy00	20	17.87	15.75	5.000
15	17015-0000-xyy00	20	28.50	18.00	11.000
16	17016-0000-xyy00	20	28.50	18.00	11.000
17	17017-0000-xyy00	20	32.75	20.80	11.000
18	17018-0000-xyy00	18	32.75	20.80	11.000
20	17020-0000-xyy00	18	34.00	22.25	11.000
22	17022-0000-xyy00	18	34.00	22.25	11.000
24	17024-0000-xyy00	18	34.00	24.25	11.000

Diameter Inches	Part Number	Gage	Height	Width	Depth
3	17203-0000-xyy00	22	7.00	5.25	5.750
4	17204-0000-xyy00	22	7.00	6.12	5.750
5	17205-0000-xyy00	22	7.00	6.12	5.750
6	17206-0000-xyy00	22	10.00	7.00	5.750
7	17207-0000-xyy00	22	11.25	8.00	5.375
8	17208-0000-xyy00	22	12.00	9.37	5.375
9	17209-0000-xyy00	22	13.25	11.00	5.500
10	17210-0000-xyy00	22	14.37	11.37	5.500
11	17211-0000-xyy00	22	16.25	13.50	5.000
12	17212-0000-xyy00	22	16.25	13.50	5.000
13	17213-0000-xyy00	22	17.87	15.75	5.000
14	17214-0000-xyy00	20	17.87	15.75	5.000
15	17215-0000-xyy00	20	28.50	18.00	11.000
16	17216-0000-xyy00	20	28.50	18.00	11.000

Gage upgrade is for collars only and can be up to (2) gages heavier than standard.

Manual Operated Sealed Slide Gates are constructed in various materials, with a seal inside to reduce air loss and friction in operation.

Gage upgrade is for collars only and can be up to (2) gages heavier than standard.

x = material 1 – galvanized 2 – galvaneal
3 – black metal 4 – 304ss 5 – 316ss
yy = gage

x = material 1 – galvanized 2 – galvaneal
3 – black metal 4 – 304ss 5 – 316ss
yy = gage

AUTOMATIC SLIDE GATE

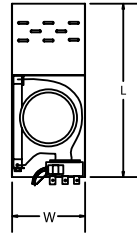

Single Cylinder

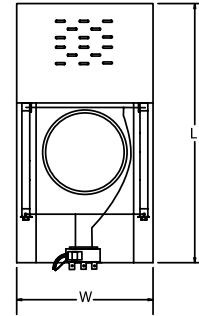

Double Cylinder

STYLE 174 — AUTOMATIC SLIDE GATE

Diameter Inches	Part Number	Cylinders	Gage	Length	Width	Depth	Center Line From Bottom
3	17403-0000-xyy00	1	22	16.0	6.30	5.5	5.25
4	17404-0000-xyy00	1	22	16.0	6.30	5.5	5.25
5	17405-0000-xyy00	1	22	17.5	7.50	5.5	6.00
6	17406-0000-xyy00	1	22	20.5	8.66	7.0	7.00
7	17407-0000-xyy00	1	22	22.0	9.44	5.0	7.25
8	17408-0000-xyy00	1	22	25.5	10.25	5.0	8.25
9	17409-0000-xyy00	2	22	33.0	17.25	12.0	14.25
10	17410-0000-xyy00	2	22	33.0	17.25	12.0	14.25
11	17411-0000-xyy00	2	22	38.5	20.00	12.0	15.50
12	17412-0000-xyy00	2	22	38.5	20.00	12.0	15.50
13	17413-0000-xyy00	2	22	41.0	23.25	12.0	16.00
14	17414-0000-xyy00	2	20	41.0	23.25	12.0	16.00
15	17415-0000-xyy00	2	20	45.0	23.25	12.0	17.25
16	17416-0000-xyy00	2	20	45.0	23.25	12.0	17.25
17	17417-0000-xyy00	2	20	48.5	25.25	12.0	18.00
18	17418-0000-xyy00	2	18	48.5	25.25	12.0	18.00
20	17420-0000-xyy00	2	18	52.5	27.25	12.0	19.00
22	17422-0000-xyy00	2	18	57.5	29.50	12.0	20.27
24	17424-0000-xyy00	2	18	57.5	29.50	12.0	20.27

Automatic Slide Gates are constructed in various materials. Standard gates operate using compressed air cylinders (75 psi/min) and electrically controlled solenoids (120V, standard, 12V, 240 available). Pneumatically operated. All electric available upon request. Gage upgrade is for collars only and can be up to (2) gages heavier than standard.

x = material 1 – galvanized 2 – galvaneal 3 – black metal 4 – 304ss 5 – 316ss
yy = gage

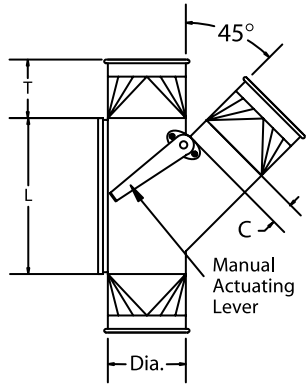

45° Standard

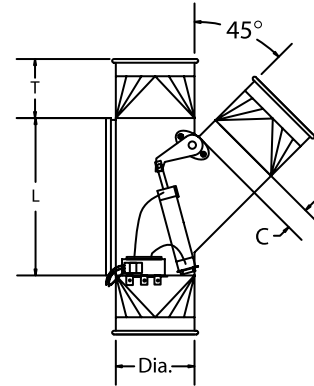

45° Standard

STYLE 182 — MANUAL DIVERTER

STYLE 184 — AUTOMATIC DIVERTER

Diameter Inches	Part Number	L	T	C	Housing Gage
3	18203-dd00-x0000	9	6	3	3/16
4	18204-dd00-x0000	10	6	3	3/16
5	18205-dd00-x0000	11	6	3	3/16
6	18206-dd00-x0000	12	6	3	3/16
7	18207-dd00-x0000	14	6	3	3/16
8	18208-dd00-x0000	16	6	3	3/16
9	18209-dd00-x0000	18	8	3	3/16
10	18210-dd00-x0000	20	8	3	3/16
11	18211-dd00-x0000	22	8	3	3/16
12	18212-dd00-x0000	24	8	3	3/16
13	18213-dd00-x0000	26	8	3	3/16
14	18214-dd00-x0000	28	8	3	3/16
15	18215-dd00-x0000	30	8	3	3/16
16	18216-dd00-x0000	32	8	3	3/16
17	18217-dd00-x0000	34	8	3	3/16
18	18218-dd00-x0000	36	8	3	3/16
20	18220-dd00-x0000	40	8	3	3/16
22	18222-dd00-x0000	44	8	3	3/16
24	18224-dd00-x0000	48	8	3	3/16

Diameter Inches	Part Number	L	T	C	Housing Gage
3	18403-dd00-x0000	9	6	3	3/16
4	18404-dd00-x0000	10	6	3	3/16
5	18405-dd00-x0000	11	6	3	3/16
6	18406-dd00-x0000	12	6	3	3/16
7	18407-dd00-x0000	14	6	3	3/16
8	18408-dd00-x0000	16	6	3	3/16
9	18409-dd00-x0000	18	8	3	3/16
10	18410-dd00-x0000	20	8	3	3/16
11	18411-dd00-x0000	22	8	3	3/16
12	18412-dd00-x0000	24	8	3	3/16
13	18413-dd00-x0000	26	8	3	3/16
14	18414-dd00-x0000	28	8	3	3/16
15	18415-dd00-x0000	30	8	3	3/16
16	18416-dd00-x0000	32	8	3	3/16
17	18417-dd00-x0000	34	8	3	3/16
18	18418-dd00-x0000	36	8	3	3/16
20	18420-dd00-x0000	40	8	3	3/16
22	18422-dd00-x0000	44	8	3	3/16
24	18424-dd00-x0000	48	8	3	3/16

Manufactured with flange bearings and sealed door. 45° and 30° available. 45° is standard.

Manufactured with flange bearings and sealed door. Standard diverters operate using double acting solenoids and air cylinders. 45° and 30° available. 45° is standard. Pneumatically operated. All electric available upon request.

x = material 3 – black metal 4 – 304ss 5 – 316ss
yy = gage
dd = degree 30 – 30 degree 45 – 45 degree

x = material 3 – black metal 4 – 304ss 5 – 316ss
yy = gage
dd = degree 30 – 30 degree 45 – 45 degree

**CUSTOM SUCTION HOODS
CUSTOM MANIFOLDS**

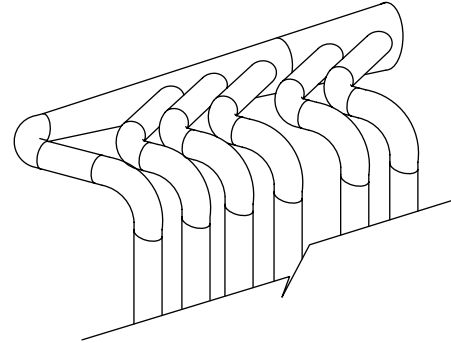
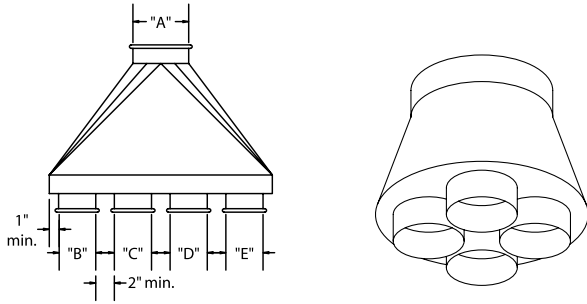

STYLE 188 — SUCTION HOODS

STYLE 159 — CUSTOM MANIFOLD

Part Number

188dd-0000-x0000

Part Number

159dd-0000-x0000

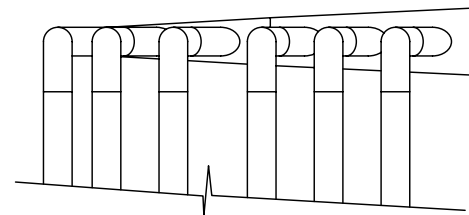
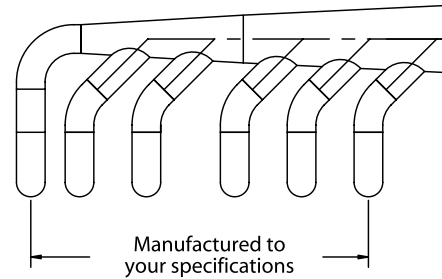
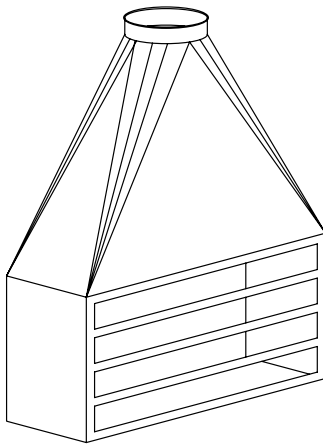

Specify Rectangle or Round construction.
Specify A, B, C, D, E and F dimensions.

Suction hoods are designed to your specifications.

Custom Manifolds are available. Consult Duct Inc. for specific design criteria for multiple manifolds.

Manifolds are designed to your specifications.

x = material 1 – galvanized 2 – galvaneal
3 – black metal 4 – 304ss 5 – 316ss
dd = diameter

x = material 1 – galvanized 2 – galvaneal
3 – black metal 4 – 304ss 5 – 316ss
dd = diameter

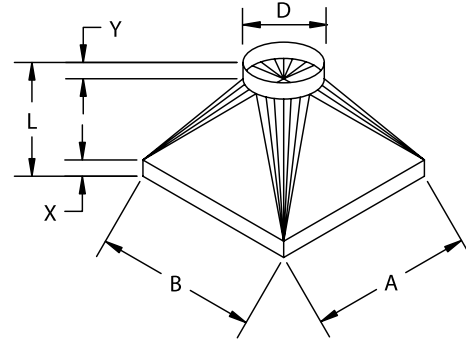

STYLE 189 — RECTANGULAR TO ROUND TRANSITION

Part Number

189dd-0000-xyy00

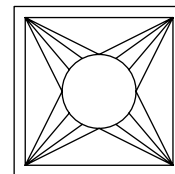
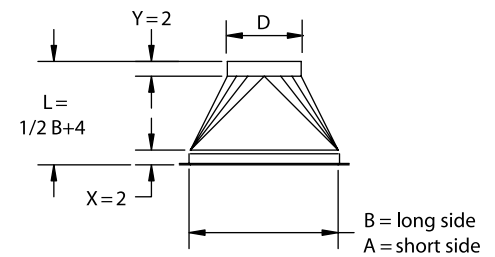

Please specify flange hole pattern

Specify dimensions A, B, D and L. Also available with flanged connections. Specify flange pattern. Flange blank of hole pattern is not provided.

Standard flange material to 1 - 1/2 x 3/16" angle. Sizes exceeding 2' 2" will be supplied with a flange.

Built to your specifications. List all required dimensions and details.

• Specify Rectangle End:	<input type="checkbox"/> Flanged	<input type="checkbox"/> Raw End	<input type="checkbox"/> Fold In	<input type="checkbox"/> Fold Out
• Flange Type:	<input type="checkbox"/> Angle Bar	<input type="checkbox"/> Flat Bar	<input type="checkbox"/> Sheet Metal	<input type="checkbox"/> Plasma Cut
• Specify Round End:	<input type="checkbox"/> Rolled	<input type="checkbox"/> Flanged	<input type="checkbox"/> Raw	<input type="checkbox"/> Hose Connection

Part Number	Quantity	D	A	B	X	Y	L	Gage	Flange Material	FLG DWG	Special Notes

x = material 1 – galvanized 2 – galvaneal 3 – black metal 4 – 304ss 5 – 316ss
dd = diameter yy = gage

**RADIAL ARM SAW HOOD
ROUTER HOOD
FLOOR SWEEP**

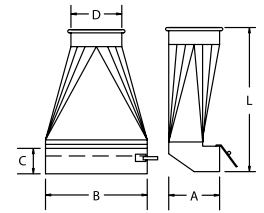
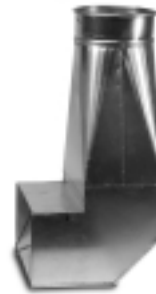
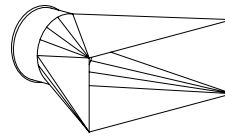
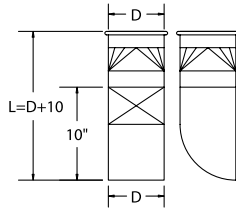

**STYLE 196 —
RADIAL ARM SAW HOOD**

STYLE 197 — ROUTER HOOD

STYLE 198 — FLOOR SWEEP

Diameter Inches	Part Number	Length Inches	Gage Standard	Gage Upgrade Up To
3	19603-0000-xyy00	15.5	22	16
4	19604-0000-xyy00	16.5	22	16
5	19605-0000-xyy00	17.5	22	16
6	19606-0000-xyy00	18.5	22	16

Diameter Inches	Part Number	Gage Standard	Gage Upgrade Up To
3	19703-0000-xyy0m	22	16
4	19704-0000-xyy0m	22	16
5	19705-0000-xyy0m	22	16
6	19706-0000-xyy0m	22	16
7	19707-0000-xyy0m	20	16
8	19708-0000-xyy0m	20	16
9	19709-0000-xyy0m	20	16
10	19710-0000-xyy0m	20	16

Diameter Inches	Part Number	Gage Standard	Gage Upgrade Up To
3	19803-0000-xyy00	22	16
4	19804-0000-xyy00	22	16
5	19805-0000-xyy00	22	16
6	19806-0000-xyy00	22	16
7	19807-0000-xyy00	20	16
8	19808-0000-xyy00	20	16
9	19809-0000-xyy00	20	16
10	19810-0000-xyy00	20	16
12	19812-0000-xyy00	20	16

x = material 1 – galvanized 2 – galvaneal
3 – black metal 4 – 304ss 5 – 316ss
yy = gage

x = material 1 – galvanized 2 – galvaneal
3 – black metal 4 – 304ss 5 – 316ss
yy = gage
m = magnet 0 – no magnet 1 – with magnet

x = material 1 – galvanized 2 – galvaneal
3 – black metal 4 – 304ss 5 – 316ss
yy = gage



STYLE 104 — STANDARD HOSE

Standard Hose is made of Santoprene designed for wide temperature ranges while maintaining flexibility. Medium weight wall provides optimum resistance to abrasion. Suited for extreme moisture and broad chemical applications. Wear strip for external abrasion. 50° to 275° F.

Color is black with yellow wear strip.

Size In Inches	Part Number
2	10402-0000-00000
2 1/2	10425-0000-00000
3	10403-0000-00000
4	10404-0000-00000
5	10405-0000-00000
6	10406-0000-00000
7	10407-0000-00000
8	10408-0000-00000
9	10409-0000-00000
10	10410-0000-00000
12	10412-0000-00000
14	10414-0000-00000
16	10416-0000-00000

This hose is in stock and available in 5' increments. Call for other sizes and applications.



105 — FDA HOSE

FDA Hose is good for positive pressure and light vacuum applications. Combines extreme flexibility with tight bending characteristics. Made of PVC, reinforced with spring steel wire. FDA approved 10° to 160° F.

Standard color is clear.

Size In Inches	Part Number
2	10502-0000-00000
2 1/2	10525-0000-00000
3	10503-0000-00000
4	10504-0000-00000
5	10505-0000-00000
6	10506-0000-00000
7	10507-0000-00000
8	10508-0000-00000
9	10509-0000-00000
10	10510-0000-00000
12	10512-0000-00000
14	10514-0000-00000
16	10516-0000-00000

This hose is in stock and available in 5' increments. Call for other sizes and applications.

Order Hose Clamps separately, see page 21.



STYLE 106 — ABRASION RESISTANT HOSE

Abrasion Resistant Hose is for dust or light material handling. Highly abrasive resistant. Extreme flexibility, with medium wall polyurethane hose construction, reinforced with a spring steel wire helix — 65° to 225° F.

Standard color is black.

Size In Inches	Part Number
2	10602-0000-00000
2 1/2	10625-0000-00000
3	10603-0000-00000
4	10604-0000-00000
5	10605-0000-00000
6	10606-0000-00000
7	10607-0000-00000
8	10608-0000-00000
9	10609-0000-00000
10	10610-0000-00000
12	10612-0000-00000
14	10614-0000-00000
16	10616-0000-00000

This hose is in stock and available in 5' increments. Call for other sizes and applications.

RIGID STEEL HOSE
FLEXIBLE STEEL HOSE
HOSE CLAMP



STYLE 107 — RIGID STEEL HOSE

STYLE 108 — FLEXIBLE STEEL HOSE

Diameter Inches	Part Number
1	10701-0000-x0000
1 1/2	10715-0000-x0000
2	10702-0000-x0000
2 1/2	10725-0000-x0000
3	10703-0000-x0000
3 1/2	10735-0000-x0000
4	10704-0000-x0000
5	10705-0000-x0000
6	10706-0000-x0000
7	10707-0000-x0000
8	10708-0000-x0000
9	10709-0000-x0000
10	10710-0000-x0000

Diameter Inches	Part Number
1	10801-0000-x0000
1 1/2	10815-0000-x0000
2	10802-0000-x0000
2 1/2	10825-0000-x0000
3	10803-0000-x0000
3 1/2	10835-0000-x0000
4	10804-0000-x0000
5	10805-0000-x0000
6	10806-0000-x0000
8	10808-0000-x0000

Diameter Inches	Part Number
2	10902-0000-40000
3	10903-0000-40000
4	10904-0000-40000
5	10905-0000-40000
6	10906-0000-40000
7	10907-0000-40000
8	10908-0000-40000
9	10909-0000-40000
10	10910-0000-40000
11	10911-0000-40000
12	10912-0000-40000
13	10913-0000-40000
14	10914-0000-40000
15	10915-0000-40000
16	10916-0000-40000
17	10917-0000-40000
18	10918-0000-40000
20	10920-0000-40000
22	10922-0000-40000
24	10924-0000-40000

Diameter ID	Approx. OD	Minimum ID Bend	Weight/Foot
1"	1 1/8"	7 1/2"	.28
1 1/2"	1 5/8"	11"	.42
2"	2 1/8"	15"	.62
2 1/2"	2 5/8"	19"	.82
3"	3 1/8"	23"	1.02
3 1/2"	3 5/8"	27"	1.26
4"	4 3/16"	30"	1.38
5"	5 3/16"	37"	1.70
6"	6 3/16"	44"	2.00
7"	7 3/16"	52"	2.50
8"	8 3/16"	60"	3.00
10"	10 3/16"	75"	4.50

Diameter ID	Approx. OD	Minimum ID Bend	Weight/Foot
1"	1 1/8"	7 1/2"	.28
1 1/2"	1 5/8"	11"	.42
2"	2 1/8"	15"	.62
2 1/2"	2 5/8"	19"	.82
3"	3 1/8"	23"	1.02
3 1/2"	3 5/8"	27"	1.26
4"	4 3/16"	30"	1.38
5"	5 3/16"	37"	1.70
6"	6 3/16"	44"	2.00
8"	8 3/16"	60"	3.00



Order as assembly to receive hose with specific ends.

x = material 1 – galvanized 4 – 304ss

x = material 1 – galvanized 4 – 304ss

Available in 304ss only.

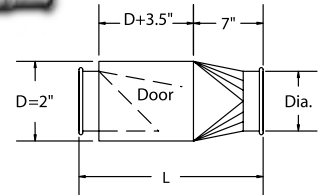
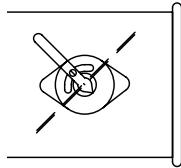

STYLE 194 — BUTTERFLY VALVE

STYLE 195 — IN-LINE BACK BLAST DAMPER

Diameter Inches	Part Number	Length Inches	Gage Standard	Gage Upgrade Up To
3	19403-0000-xyy00	8	22	18
4	19404-0000-xyy00	8	22	18
5	19405-0000-xyy00	8	22	18
6	19406-0000-xyy00	8	22	18
7	19407-0000-xyy00	8	22	18
8	19408-0000-xyy00	13	22	16
9	19409-0000-xyy00	13	22	16
10	19410-0000-xyy00	13	22	16
11	19411-0000-xyy00	13	22	16
12	19412-0000-xyy00	13	22	16
13	19413-0000-xyy00	13	22	16
14	19414-0000-xyy00	17	20	16
15	19415-0000-xyy00	17	20	16
16	19416-0000-xyy00	17	20	16
17	19417-0000-xyy00	17	20	16
18	19418-0000-xyy00	23	18	14
20	19420-0000-xyy00	23	18	14
22	19422-0000-xyy00	23	18	14
24	19424-0000-xyy00	25	18	14

Diameter Inches	Part Number	Length Inches	Gage Standard	Gage Upgrade Up To
3	19503-0000-xyy00	15.5	22	18
4	19504-0000-xyy00	16.5	22	18
5	19505-0000-xyy00	17.5	22	18
6	19506-0000-xyy00	18.5	22	18
7	19507-0000-xyy00	19.5	22	18
8	19508-0000-xyy00	20.5	22	16
9	19509-0000-xyy00	21.5	22	16
10	19510-0000-xyy00	22.5	22	16
11	19511-0000-xyy00	23.5	22	16
12	19512-0000-xyy00	24.5	22	16
13	19513-0000-xyy00	25.5	22	16
14	19514-0000-xyy00	26.5	20	16
15	19515-0000-xyy00	27.5	20	16
16	19516-0000-xyy00	28.5	20	16
17	19517-0000-xyy00	32.5	20	16
18	19518-0000-xyy00	35.5	18	14
20	19520-0000-xyy00	39.5	18	14
22	19522-0000-xyy00	39.5	18	14
24	19524-0000-xyy00	41.5	18	14
26	19526-0000-xyy00	43.5	18	14
28	19528-0000-xyy00	45.5	18	14
30	19530-0000-xyy00	47.5	18	14
32	19532-0000-xyy00	49.5	18	14
34	19534-0000-xyy00	51.5	18	14
36	19536-0000-xyy00	53.5	18	14
38	19538-0000-xyy00	55.5	18	14
40	19540-0000-xyy00	57.5	18	14

Standard locking quadrant handle enables users to regulate air volumes. Not recommended for material conveying.

In-Line Back Blast Damper reduces backward air flow in system.

x = material 1 – galvanized 2 – galvaneal
3 – black metal 4 – 304ss 5 – 316ss
yy = gage

x = material 1 – galvanized 2 – galvaneal
3 – black metal 4 – 304ss 5 – 316ss
yy = gage

VIBRATION ISOLATOR ADJUSTABLE BLEED-IN VALVE

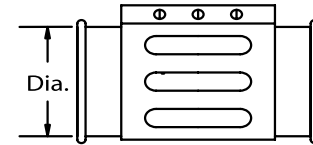
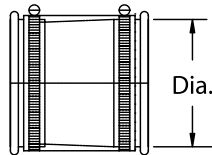

STYLE 192 — VIBRATION ISOLATOR

STYLE 193 — ADJUSTABLE BLEED-IN VALVE

Diameter Inches	Part Number	Length Inches	Gage Standard	Gage Upgrade Up To
3	19203-0000-xyy00	6.5	24	18
4	19204-0000-xyy00	6.5	22	18
5	19205-0000-xyy00	6.5	22	18
6	19206-0000-xyy00	6.5	22	18
7	19207-0000-xyy00	6.5	22	18
8	19208-0000-xyy00	6.5	22	16
9	19209-0000-xyy00	6.5	22	16
10	19210-0000-xyy00	6.5	22	16
11	19211-0000-xyy00	6.5	22	16
12	19212-0000-xyy00	6.5	22	16
13	19213-0000-xyy00	6.5	22	16
14	19214-0000-xyy00	6.5	20	16
15	19215-0000-xyy00	6.5	20	16
16	19216-0000-xyy00	6.5	20	16
17	19217-0000-xyy00	6.5	20	16
18	19218-0000-xyy00	6.5	18	14
20	19220-0000-xyy00	6.5	18	14
22	19222-0000-xyy00	6.5	18	14
24	19224-0000-xyy00	7	18	14
26	19226-0000-xyy00	7	18	14
28	19228-0000-xyy00	7	18	14
30	19230-0000-xyy00	7	18	14
32	19232-0000-xyy00	8	18	14
34	19234-0000-xyy00	8	18	14
36	19236-0000-xyy00	8	18	14
38	19238-0000-xyy00	8	18	14
40	19240-0000-xyy00	8	18	14

Diameter Inches	Part Number	Length Inches	Gage Standard	Gage Upgrade Up To
3	19303-0000-xyy00	2	22	18
4	19304-0000-xyy00	2	22	18
5	19305-0000-xyy00	3	22	18
6	19306-0000-xyy00	3	22	18
7	19307-0000-xyy00	4	22	18
8	19308-0000-xyy00	4	22	16
9	19309-0000-xyy00	5	22	16
10	19310-0000-xyy00	5	22	16
11	19311-0000-xyy00	6	22	16
12	19312-0000-xyy00	6	22	16
13	19313-0000-xyy00	6	22	16
14	19314-0000-xyy00	7	20	16
15	19315-0000-xyy00	7	20	16
16	19316-0000-xyy00	8	20	16
17	19317-0000-xyy00	8	20	16
18	19318-0000-xyy00	9	18	14
20	19320-0000-xyy00	10	18	14
22	19322-0000-xyy00	11	18	14
24	19324-0000-xyy00	12	18	14

Adjustable Bleed-In Valve allows the introduction of air to balance the system.

Vibration Isolator reduces vibration between fan and ducting system.

x = material 1 – galvanized 2 – galvaneal
3 – black metal 4 – 304ss 5 – 316ss
yy = gage

x = material 1 – galvanized 2 – galvaneal
3 – black metal 4 – 304ss 5 – 316ss
yy = gage

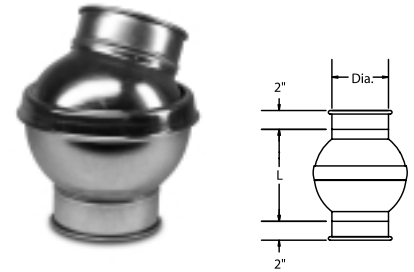
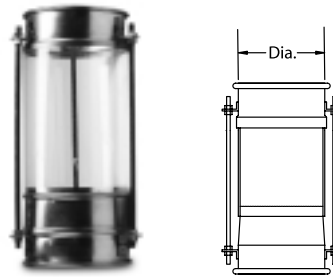
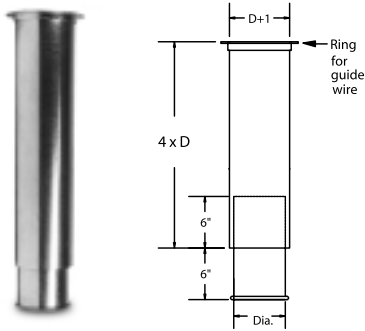

**STYLE 190 —
NO-LOSS STACK HEAD**

**STYLE 191 — ANTI-STATIC
SIGHT GLASS**

Diameter Inches	Part Number	Gage Standard	Gage Upgrade Up To
3	19003-0000-xyy00	22	18
4	19004-0000-xyy00	22	18
5	19005-0000-xyy00	22	18
6	19006-0000-xyy00	22	18
7	19007-0000-xyy00	22	18
8	19008-0000-xyy00	22	16
9	19009-0000-xyy00	22	16
10	19010-0000-xyy00	22	16
11	19011-0000-xyy00	22	16
12	19012-0000-xyy00	22	16
13	19013-0000-xyy00	22	16
14	19014-0000-xyy00	20	16
15	19015-0000-xyy00	20	16
16	19016-0000-xyy00	20	16
17	19017-0000-xyy00	20	16
18	19018-0000-xyy00	18	14
20	19020-0000-xyy00	18	14
22	19022-0000-xyy00	18	14
24	19024-0000-xyy00	18	14
26	19026-0000-xyy00	18	14
28	19028-0000-xyy00	18	14
30	19030-0000-xyy00	18	14
32	19032-0000-xyy00	18	14
34	19034-0000-xyy00	18	14
36	19036-0000-xyy00	18	14
38	19038-0000-xyy00	18	14
40	19040-0000-xyy00	18	14

No-Loss Stack Head provides weather protection while it eliminates back pressure on the fan. Flanged end provides for wire guide security.

x = material 1 – galvanized 2 – galvaneal
3 – black metal 4 – 304ss 5 – 316ss
yy = gage

Diameter Inches	Part Number	Gage Standard	Gage Upgrade Up To
3	19103-0000-xyy00	24	18
4	19104-0000-xyy00	22	18
5	19105-0000-xyy00	22	18
6	19106-0000-xyy00	22	18
7	19107-0000-xyy00	22	18
8	19108-0000-xyy00	22	16
9	19109-0000-xyy00	22	16
10	19110-0000-xyy00	22	16
11	19111-0000-xyy00	22	16
12	19112-0000-xyy00	22	16
13	19113-0000-xyy00	22	16
14	19114-0000-xyy00	20	16
15	19115-0000-xyy00	20	16
16	19116-0000-xyy00	20	16
17	19117-0000-xyy00	20	16
18	19118-0000-xyy00	18	14

Anti-Static Sight Glass provides viewing of material flow. Viewing area material is acrylic.

x = material 1 – galvanized 2 – galvaneal
3 – black metal 4 – 304ss 5 – 316ss
yy = gage

Diameter Inches	Part Number	Gage Standard	Length
3	14503-0000-xyy00	20	9.50
4	14504-0000-xyy00	20	9.50
5	14505-0000-xyy00	20	10.75
6	14506-0000-xyy00	20	10.75
7	14507-0000-xyy00	20	10.75
8	14508-0000-xyy00	18	14.00
9	14509-0000-xyy00	18	15.00
10	14510-0000-xyy00	18	15.00
12	14512-0000-xyy00	16	15.00
14	14514-0000-xyy00	14	17.50

Allows 22.5° of movement from center.

x = material 1 – galvanized
4 – 304ss 5 – 316ss
yy = gage

ANGLE RING FLANGE

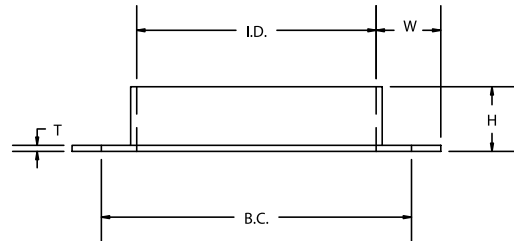

STYLE 123 — ANGLE RING FLANGE

Diameter Inches	Part Number	ID	H	W	T	BC	Number Of Bolts	Diameter Of Bolt Hole
3	12303-0000-x0000	3 1/16"	1"	1"	10ga.	4 5/16"	6	9/32"
4	12304-0000-x0000	4 1/16"	1"	1"	10ga.	5 5/16"	6	9/32"
5	12305-0000-x0000	5 1/16"	1"	1"	10ga.	6 5/16"	6	9/32"
6	12306-0000-x0000	6 1/8"	1 1/4"	1 1/4"	1/8"	7 5/16"	6	9/32"
7	12307-0000-x0000	7 1/8"	1 1/4"	1 1/4"	1/8"	8 1/2"	6	3/8"
8	12308-0000-x0000	8 1/8"	1 1/4"	1 1/4"	1/8"	9 9/16"	6	3/8"
9	12309-0000-x0000	9 1/8"	1 1/4"	1 1/4"	1/8"	10 5/8"	6	7/16"
10	12310-0000-x0000	10 1/8"	1 1/4"	1 1/4"	1/8"	11 13/16"	6	7/16"
11	12311-0000-x0000	11 1/8"	1 1/4"	1 1/4"	1/8"	12 3/4"	6	7/16"
12	12312-0000-x0000	12 3/16"	1 1/2"	1 1/2"	1/8"	14"	8	7/16"
13	12313-0000-x0000	13 3/16"	1 1/2"	1 1/2"	1/8"	15"	8	7/16"
14	12314-0000-x0000	14 3/16"	1 1/2"	1 1/2"	1/8"	16"	8	7/16"
15	12315-0000-x0000	15 3/16"	1 1/2"	1 1/2"	1/8"	17"	8	7/16"
16	12316-0000-x0000	16 3/16"	1 1/2"	1 1/2"	3/16"	18"	8	7/16"
17	12317-0000-x0000	17 3/16"	1 1/2"	1 1/2"	3/16"	19"	8	7/16"
18	12318-0000-x0000	18 3/16"	1 1/2"	1 1/2"	3/16"	20"	8	7/16"
19	12319-0000-x0000	19 3/16"	1 1/2"	1 1/2"	3/16"	20 3/4"	12	7/16"
20	12320-0000-x0000	20 3/16"	1 1/2"	1 1/2"	3/16"	21 3/4"	12	7/16"
21	12321-0000-x0000	21 3/16"	1 1/2"	1 1/2"	3/16"	22 3/4"	12	7/16"
22	12322-0000-x0000	22 3/16"	1 1/2"	1 1/2"	3/16"	23 3/4"	12	7/16"
23	12323-0000-x0000	23 3/16"	1 1/2"	1 1/2"	3/16"	24 7/8"	12	7/16"
24	12324-0000-x0000	24 3/16"	1 1/2"	1 1/2"	3/16"	25 7/8"	12	7/16"
25	12325-0000-x0000	25 3/16"	2"	2"	3/16"	26 7/8"	16	7/16"
26	12326-0000-x0000	26 3/16"	2"	2"	3/16"	28 3/8"	16	7/16"
27	12327-0000-x0000	27 3/16"	2"	2"	3/16"	29 3/8"	16	7/16"
28	12328-0000-x0000	28 3/16"	2"	2"	3/16"	30 3/8"	16	7/16"
29	12329-0000-x0000	29 3/16"	2"	2"	3/16"	31 3/8"	16	7/16"
30	12330-0000-x0000	30 3/16"	2"	2"	3/16"	32 3/8"	16	7/16"
31	12331-0000-x0000	31 3/16"	2"	2"	3/16"	33 3/8"	16	7/16"
32	12332-0000-x0000	32 3/16"	2"	2"	3/16"	34 3/8"	16	7/16"
33	12333-0000-x0000	33 3/16"	2"	2"	3/16"	35 3/8"	16	7/16"
34	12334-0000-x0000	34 3/16"	2"	2"	3/16"	36 3/8"	16	7/16"
35	12335-0000-x0000	35 3/16"	2"	2"	3/16"	37 3/8"	16	7/16"
36	12336-0000-x0000	36 3/16"	2"	2"	3/16"	38 3/8"	16	7/16"
37	12337-0000-x0000	37 3/16"	2"	2"	3/16"	39 3/8"	24	7/16"
38	12338-0000-x0000	38 3/16"	2"	2"	3/16"	40 3/8"	24	7/16"
39	12339-0000-x0000	39 3/16"	2"	2"	3/16"	41 3/8"	24	7/16"
40	12340-0000-x0000	40 3/16"	2"	2"	3/16"	42 3/8"	24	7/16"
42	12342-0000-x0000	42 3/16"	2"	2"	3/16"	44 3/8"	24	7/16"
44	12344-0000-x0000	44 3/16"	2"	2"	3/16"	46 3/8"	24	7/16"
46	12346-0000-x0000	46 3/16"	2"	2"	3/16"	48 3/8"	24	7/16"
48	12348-0000-x0000	48 3/16"	2"	2"	3/16"	50 3/8"	24	7/16"
50	12350-0000-x0000	50 3/16"	2"	2"	3/16"	52 3/8"	24	7/16"

Larger sizes available. Call for availability.

x = material
 1 – galvanized
 2 – black metal
 4 – 304ss
 5 – 316ss

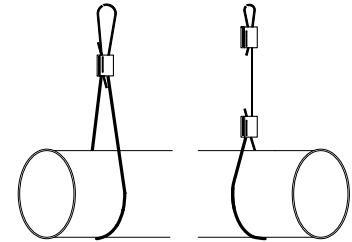
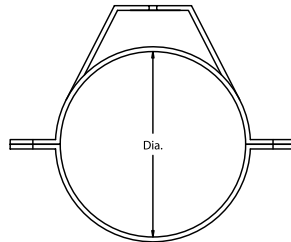
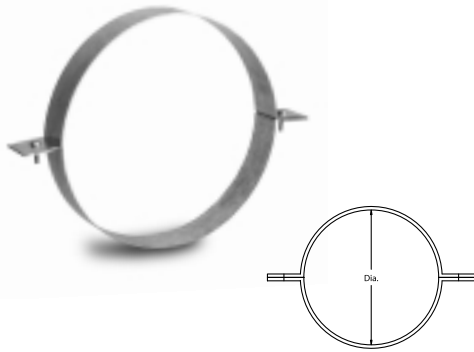

STYLE 166 — TR PIPE HANGER

Diameter Inches	Part Number
3	16503-0000-x0000
4	16504-0000-x0000
5	16505-0000-x0000
6	16506-0000-x0000
7	16507-0000-x0000
8	16508-0000-x0000
9	16509-0000-x0000
10	16510-0000-x0000
11	16511-0000-x0000
12	16512-0000-x0000
13	16513-0000-x0000
14	16514-0000-x0000
15	16515-0000-x0000
16	16516-0000-x0000
17	16517-0000-x0000
18	16518-0000-x0000
20	16520-0000-x0000
22	16522-0000-x0000
24	16524-0000-x0000
26	16526-0000-x0000
28	16528-0000-x0000
30	16530-0000-x0000
32	16532-0000-x0000
34	16534-0000-x0000
36	16536-0000-x0000
38	16538-0000-x0000
40	16540-0000-x0000

Pipe Hanger is constructed in various materials and comes complete with nuts and bolts. 3"-22" made in 14 gage material, over 22" = 3/16" flat bar.

x = material 1 – galvanized 2 – galvaneal
3 – black metal 4 – 304ss 5 – 316ss

Diameter Inches	Part Number
3	16603-0000-x0000
4	16604-0000-x0000
5	16605-0000-x0000
6	16606-0000-x0000
7	16607-0000-x0000
8	16608-0000-x0000
9	16609-0000-x0000
10	16610-0000-x0000
11	16611-0000-x0000
12	16612-0000-x0000
13	16613-0000-x0000
14	16614-0000-x0000
15	16615-0000-x0000
16	16616-0000-x0000
17	16617-0000-x0000
18	16618-0000-x0000
20	16620-0000-x0000
22	16622-0000-x0000
24	16624-0000-x0000
26	16626-0000-x0000
28	16628-0000-x0000
30	16630-0000-x0000
32	16632-0000-x0000
34	16634-0000-x0000
36	16636-0000-x0000
38	16638-0000-x0000
40	16640-0000-x0000

TR Pipe Hanger is constructed in various materials and comes complete with nuts and bolts. 3"-22" made in 14 gage material, over 22" = 3/16" flat bar.

x = material 1 – galvanized 2 – galvaneal
3 – black metal 4 – 304ss 5 – 316ss

Item	Part Number
1/8" Cable	16405-0000-00000
3/16" Cable	16410-0000-00000
Cable Lock	16430-0000-00000

1/8" Cable, 3/16" Cable and Cable Lock sold separately. Order cable by the foot.

**PIPE BRACING
BEAM CLAMP
THREADED ROD**



STYLE 168 — PIPE BRACING

STYLE 167 — THREADED ROD

Diameter Inches	Part Number
1/2"	16800-0000-00000

Galvanized 1/2" pipe bracing is supplied in 10' lengths. Customer cut to length, flatten ends, drill holes for finished product.

Diameter Inches	Part Number
1/2"	16900-0000-00000

Quick connection of pipe brace to roof supports.

Diameter Inches	Part Number
3/8"	16700-0000-00000

NEW ACCOUNTS

Applications for credit are normally processed in two working days, for businesses with a Dunn and Bradstreet rating. Orders for new accounts may require pre-payment, C.O.D. or freight collect terms.

GENERAL CONDITIONS OF SALE

Contract and Acceptance: The terms and conditions of acceptance of sale set forth herein, and all drawings, specifications, descriptions and other documents attached hereto and incorporated herein by reference constitute the entire agreement between Duct Incorporated (seller) and the buyer. Seller's acceptance of this order is expressly conditioned by the buyer's assent to the terms contained herein. The terms and conditions of the Seller's proposal (if any) and acknowledgement shall prevail over any conflicting or different terms in buyer's order unless buyer notifies seller in writing of its objections thereto within (15) fifteen days from receipt of seller's acknowledgement. The failure of Seller to object to any provision in conflict herewith whether contained in Buyer's purchase order or otherwise, shall not be construed as a waiver of the provisions hereof nor as an acceptance thereof. Seller's proposal is only preliminary unless it is otherwise confirmed. All payments shall be made to the address stated on the invoice.

CLAIMS FOR SHORTAGES

Any claim for loss, breakage (obvious or concealed) are Buyer's responsibility and should be made to the carrier. Seller will render Buyer reasonable assistance in securing satisfactory adjustment of such claims. Any notices of shortages or other errors must be made in writing to Seller within 15 days after receipt of shipment. Failure to give such notice shall constitute unqualified acceptance and a waiver of all claims by Buyer. Risk of loss for damage to the products sold hereunder passes to Buyer upon delivery to the carrier regardless of who pays shipping costs.

WARRANTIES

The Seller warrants that the products sold hereunder conform to any applicable drawings and specifications accepted in writing by Seller and will be free from any defects in material and workmanship which become apparent under normal use, and of which Buyer gives written notice to Seller within a period of 6 months from the date of installation or 12 months from the date of shipment, whichever period first expires. If, within that period, the Seller receives from Buyer written notice of any alleged defect in, or non-conformance of, any product and if, in Seller's sole judgement, the product does not conform or is found to be defective in material or workmanship, then Buyer shall, at Seller's request, return the part or product F.O.B. Seller's shipping point and Seller, at its option and expenses, shall repair or replace the defective part or product or repay the Buyer the full price paid for such part or product by Buyer. Dismounting and reinstallation of defective or nonconforming parts is done on Buyer's expense. Warranty for delivery of spare parts or replacement for non-conforming parts expires when warranty for original equipment expires. Any repayment of purchase price shall be without interest. Seller's sole responsibility, and Buyer's exclusive remedy hereunder shall be limited to such repair, replacement, or repayment of the purchase price as above provided. **There are no other warranties, expresses, statutory or implied, including those of merchantability, quality or fitness for purpose, nor any affirmation of fact or representation that extends beyond the description on the face hereof. The warranties of Seller do not cover and Seller makes no warranty with respect to:**

- a) failures not reported to Seller within the warranty period specified above;
- b) failure or damage due to misapplication, abuse, improper installation or abnormal conditions of temperature, dirt or other corrosive matter;

- c) failures due to operation, either intentional or otherwise, above rated capacities or in an otherwise improper manner;
- d) products which have been in any way tampered with or altered by anyone other than an authorized representative of Seller;
- e) products damaged in shipment or otherwise without fault of Seller;
- f) expenses incurred by Buyer in an attempt to repair or rework any alleged defective product, and
- g) defects in material and workmanship which are attributable to drawings and specifications provided by Buyer.

LIMITATION OF LIABILITY

Seller's sole responsibility and Buyer's sole and exclusive remedy with respect to any breach of warranty or guarantee under this agreement shall be limited to repair, replacement or repayment of the purchase price at Seller's sole option. Seller's total responsibility and liability for any and all claims, damages of any nature, losses, liabilities or costs of corrective efforts, including but not limited to those relating to any warranty or guarantee arising out of or related to performance of this agreement or the products covered hereunder or the performance thereof shall not exceed the purchase price. In no event shall Seller be liable for any special, indirect, incidental or consequential damages of any character; including but not limited to, loss of use or productive facilities or equipment, lost profits, property damage, expense incurred in reliance on Seller's performance hereunder, or lost production, whether suffered by Buyer or any third party. Seller disclaims all liability for any and all costs, claims, demands, charges, expenses or other damages, either direct or indirect, incident to all property damages arising out of any cause of action based on strict liability.

COSTS & EXPENSES

Buyer agrees to pay Seller all costs and expenses, including reasonable attorney's fees (including those on appeal) incurred by Seller in exercising any of its rights and remedies hereunder, including specifically the collection of any outstanding balance owed to Seller and Buyer.

MISCELLANEOUS

The rights and duties of the parties and construction and effect of all provisions hereof shall be governed by and construed according to the law of the State of Nevada, United States of America, except as otherwise provided herein. Failure of Seller to insist in any one of more instances upon the performance of any of the terms and conditions of this contract or the failure of Seller to exercise any of its rights hereunder shall not be construed as a waiver or relinquishment of any such term, condition, or right hereunder and shall not affect Seller's right to insist upon strict performance and compliance with regard to any unexecuted portions of this contract or future performance of these terms and conditions.

RETURN POLICY

Customer must fill out a RGA (Return Goods Authorization) Worksheet. Absolutely no shipment will be accepted by Duct Incorporated without a RGA. A RGA can not be issued on an order that is older than 90 days from original order ship date. Issued RGA forms will be paid for 30 days from issue date. There will be a 25% charge for re-inventorying and re-stocking of returned components. Specific items that can be returned **MUST BE RESELLABLE** components: Pipe, Standard Elbows, Adjustable Nipples, Hangers, Blast Gates and Clamps. **CUSTOM CONFIGURATIONS ARE NON-RETURNABLE.** Return freight costs to our manufacturing site in NM are returnee's responsibility.

TECHNICAL INFORMATION SHEET



ADAPTING TO AN EXISTING SYSTEM

There may be cases when you want to apply Duct Incorporated duct to an existing system. Duct Incorporated makes adapters for this purpose. These can be provided in flanged-to-rolled by simply requesting machine adapters that can be attached to the end of existing duct (spiral or straight) so that Duct Incorporated LaserLock™ ducting can be used.

HINTS FOR ORDERING

- Order one clamp per Duct Incorporated component: 1 duct = 1 clamp, 2 elbows = 2 clamps
- Specify dimensional information to speed up process:
 - TRANSITIONS - A, B, D, L, X, Y
 - BRANCHES - A x B x C
 - IN-CUTS - A and B
 - REDUCERS - All Dimensions
- Specify end configuration required:
 - Rolled
 - Flanged
 - Hose
 - I.D. Connection
 - O.D. Connection
- Look for 60° elbows to compliment 30° branch orders (standard is 45° branch and 45° elbows). This is a typical application since the two components will create a perpendicular run to the trunk line.
- Specify your needs (i.e., flange styles, hole patterns, I.D., O.D.) when applicable. Typical parts requiring flanges will be parts that connect to filters, fans or other types of equipment.
- How to Read the Part Number:

13003		-ddcc-		xyy		00	
Style Number	Diameter	Degree	CLR	Material	Gage	Special Use	

LEAKAGE RATES

All "fit or clamp together" ducting systems allow for some degree of leakage and are not sold as airtight systems. Duct Incorporated offers special clamp gasket material for high heat that may be enhanced by applying sealants to the individual rolled ends. However, the Duct Incorporated system is sold as a quick way of installing and modifying ductwork while retaining the usability of each component. Duct Incorporated ducting is meant to be taken apart, re-assembled, stored and moved. Completely eliminating the possibility for leakage jeopardizes the inherent benefits of the duct system.

Duct Incorporated is designed to provide tight sealing and efficient airflow under negative pressures. The following information is provided for piping situations where fan sizing is of extreme importance. This data was obtained using standard components and was performed in accordance with SMACNA, "HVAC Air Duct Leakage Test Manual." This chart gives the leakage rate per joint of duct at various pressures. To utilize the chart, count the number of clamps (this equals the number of joints) per size and multiply by the number given beside the corresponding diameter under the applicable pressure. These numbers assume that the product is correctly installed free of dents in the joining ends, and that the gasket is in place. Special gasket materials and sealants will increase sealing capabilities.

While Duct Incorporated is currently unaware of any method of evaluating dust collection piping alone, the following data is presented using the criteria for all duct, including HVAC. This data is presented only for the purpose of indicating acceptability of Duct Incorporated ducting for dust/fume removal in negative pressure situations and should not be confused with ducting that uses tape or gaskets as sealants in the positive conveyance of air.

WG Leakage Rate in CFM per Duct Incorporated Joint

Diameter of Pipe	Pressures Inches						
	5"	7.5"	10"	15"	20"	25"	30"
3.0	0.8	1.1	1.3	1.6	1.9	2.1	2.4
4.0	0.8	1.1	1.3	1.6	1.9	2.1	2.4
5.0	0.8	1.1	1.3	1.6	1.9	2.1	2.4
6.0	0.8	1.1	1.3	1.6	1.9	2.1	2.4
7.0	0.8	1.1	1.3	1.6	1.9	2.1	2.4
8.0	0.8	1.1	1.3	1.6	1.9	2.1	2.4
9.0	0.8	1.1	1.3	1.6	1.9	2.1	2.4
10.0	0.8	1.1	1.3	1.6	1.9	2.1	2.4
12.0	2.2	3.0	3.6	4.5	5.8	6.4	7.5
14.0	3.2	4.1	4.5	5.5	6.5	7.5	8.5
16.0	3.2	4.1	4.5	6.2	7.0	8.3	9.0
18.0	3.2	4.1	4.5	6.2	7.0	8.3	9.0
20.0	4.3	5.8	6.3	7.5	8.5	10.5	12.0
22.0	4.3	5.8	6.3	7.5	8.5	10.5	12.0
24.0	4.6	6.0	6.3	7.5	8.5	10.5	12.0

Leakage Determined in Accordance with SMACNA

Duct Size	Avg. Leakage per 100 sq. ft. 5" SP	10" SP	SMACNA Class
4" - 6"	13 CFM	20 CFM	5
7" - 10"	7 CFM	12 CFM	3
12" - 22"	14 CFM	21 CFM	5

PAINT USED ON SPOT WELDS

Krylon Industries. Tough Coat, Acrylic Enamel #1760 Aluminum.

COLLAPSIBILITY STRENGTH

Duct Incorporated ducting has been tested for strength/collapsibility. The piping was exposed to constant positive pressure and vacuum to a maximum capacity of 85" WG. None of the pipe showed signs of deformation during the test.

INSTALLING AN IN-CUT OR TAP-IN BRANCH

- Temporarily place the In-Cut or Tap-In on the main trunk in the required position, and while holding in place, mark the interior of the branch on trunk line where it is to be cut.
- Take down In-Cut and drill a starter hole in the main trunk along the line traced from the branch. Then using metal snips or a reciprocating saw, cut out metal piece that has been traced out. File or grind any sharp edges to insure efficient flow.

- Now use an industrial strength silicone sealant to seal between In-Cut base and main trunk.
- Use small sheet metal screws or a banding type clamp material to secure In-Cut to the main trunk.

PAINTING GALVANIZED COMPONENTS

- Wash down all components with an industrial degreaser, insuring that no oils or residues are left behind.
- Apply an epoxy primer in a light coating.
- For final coat, apply an acrylic water base paint.

CAULKING USED ON SEAMS OF COMPONENTS

Scotch Seal® 2084 metal sealant, 3M ID #62-2084-2631-2. Ingredients: acetone, acrylonitrile, kaolin, phenolic resin, rosin ester salicyclic acid, aluminum pigment zinc oxide, amorphous silica.

DUCT INCORPORATED FLANGE/DUCT SPECIFICATIONS

COMPONENT MATERIAL

- Components constructed of galvanized steel sheets produced by the Continuous Galvanizing process, which conforms to Lockforming Quality ASTM A-527, and Commercial Quality ASTM A-526. Galvanized sheeting is produced with a minimum spangle.
- Components constructed of stainless steel will be 304 2B finish. (2B finish is annealed, pickled and bright cold rolled.)

DUCTWORK

- Rolled – Material sheet blanks are 5' long and rolled with a single longitudinal welded seam. The ends of the duct are then formed at each end, thus producing a rolled edge on both ends of the duct, and creating a reinforcement every five feet.
- Flanged – Material sheet blanks are 5' long and rolled with a single longitudinal welded seam. An angle ring flange is placed on the end of duct.
- All rolled duct joints are secured by using a clamp. Locking pins are installed to insure that clamps do not release once installed.

DUCT SHOULD BE SUPPORTED AS FOLLOWS

- 3" – 11" diameter on 20' centers.
- 12" – 24" diameter on 15' centers.

Supports should be installed to provide lateral stability to the entire piping system. Each installation is unique and should be evaluated.

DUCT DIAMETERS FOR ROLLED AND FLANGED AS FOLLOWS

Rolled

- 3" – 18" available in 1" increments.
- 18" – 24" available in 2" increments.

Flanged

- 3" – 40" available in 1" increments
- 42" – 60" available in 2" increments

DEFINITIONS OF END CONFIGURATIONS

- ANGLE FLANGE:** Parts indicated in catalog can be provided with a standard angle flange end. (See page 23 for angle flange hole pattern.)
- FLAT FLANGE:** Parts indicated in catalog can be provided with a standard flat flange end that is either supplied blank or with a specific hole pattern provided by the customer.
- I.D. or O.D.:** Parts indicated in catalog (e.g., Machine Adapters) can be provided raw without the standard rolled end. The customer must specify whether or not they want I.D. or O.D. dimensions. This would normally occur when attempting to connect Duct Incorporated ducting to an existing spiral duct system.
- ROLLED:** This is the standard end provided on the Duct Incorporated **LaserLock™** ducting. These are specially machined double rolled lips for added strength. The patent-pending clamp connects the rolled ends together.
- HOSE:** Parts indicated in catalog can be provided with a hose connection end, when needed, to allow for easy connection to hose for areas when a hose adapter cannot be used because of space constraints.

VELOCITY REQUIREMENTS FOR TYPICAL MATERIALS

Conveyed Material	Velocity FPM	Example
Gases, Smoke, Vapor	1000-2000	All Vapors, Gases and Smoke
Fumes	2000-2500	Welding
Very Fine, Light Dust	2500-3000	Cotton Lint, Litho Powder, Wood Flour
Dry Dusts & Powders	3500-4000	Light Shavings, Rubber Dust, Soap Dust
Industrial Dust	3000-4000	Grinding/Buffering Dust, Granite/Brick/Clay Dust
Heavy Dusts	4000-4500	Heavy/Wet Sawdust, Metal Turnings, Sand Blast Dust, Wood Blocks
Heavy or Moist	4500+	Moist Cement Dust, Quick-Lime Dust, Sticky Buffering Lint

RULE OF THUMB - LABOR GUIDELINES

The following methods should be used for comparison and budgetary purposes only! By no means should they be used to confirm a job installation.

A + B = Man Hours

A. Straight runs and trunk lines

- Rolled duct = 15 man hours per 100'
- Flanged duct = 20 man hours per 100'

B. Machine connections

- Machine with 3 or more ports = 4 man hours per port
- Machine with 1-2 ports = 3 man hours per port

Quick method = (total number of ports) x 3 hours each = Y
Y x 2 = Ducting System Total Man Hours

LASERLOCK SECRET TO ELIMINATING UP TO 50% OF INSTALLATION TIME



INSTRUCTIONS FOR INSTALLING A SLIP JOINT

LaserLock™ Slip Joint telescopes in length to eliminate wasted parts due to improper measurements.



1

Measure the distance to be spanned.

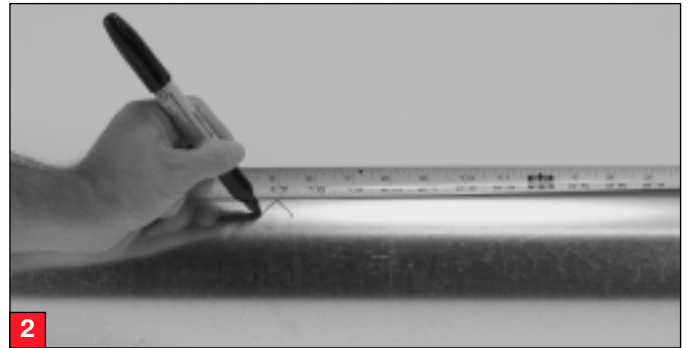

2

Mark pipe approximately 4" less than the distance needed.

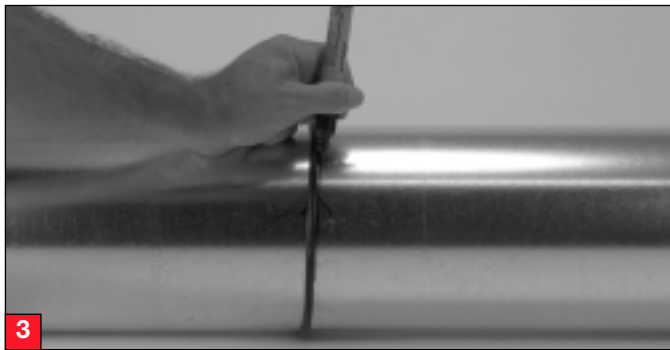

3

Mark for cutting. Use o-ring provided.

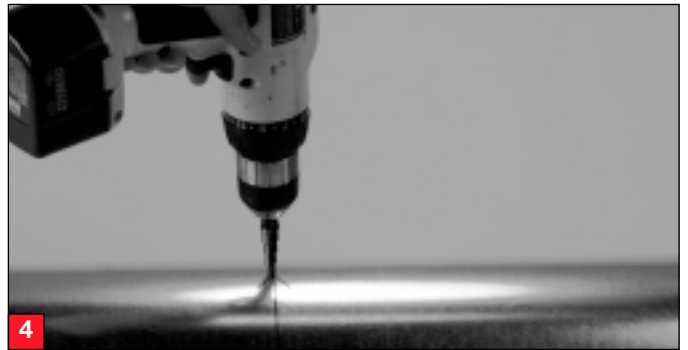

4

Drill access hole, then cut with metal snips or saw along line, then remove burrs.

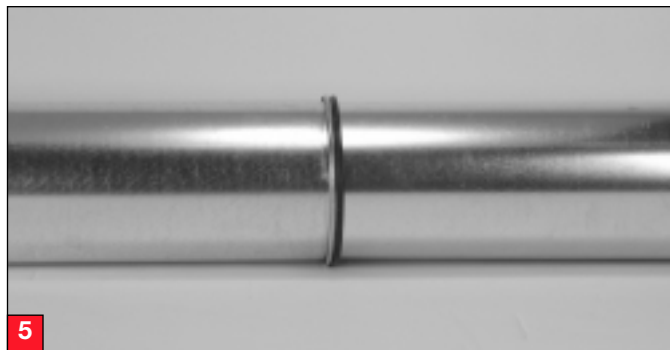

5

Slide slip joint over cut end of pipe and adjust its length.

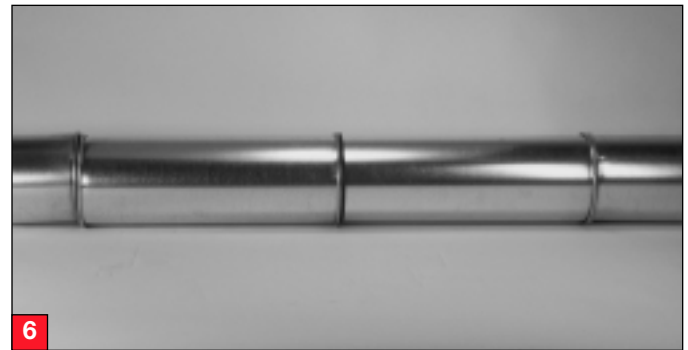

6

Insert slip joint assembly to complete connection.

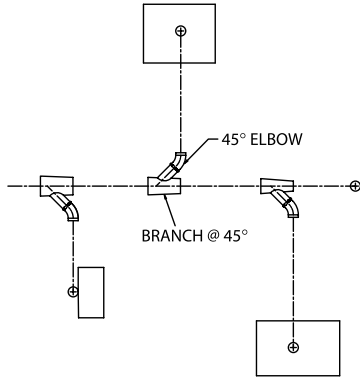

1

Connect all 45° branch pieces and 45° elbows to produce a required 90° angle. Lay out branch and elbow assemblies on the floor in line with machine entry points as shown above.

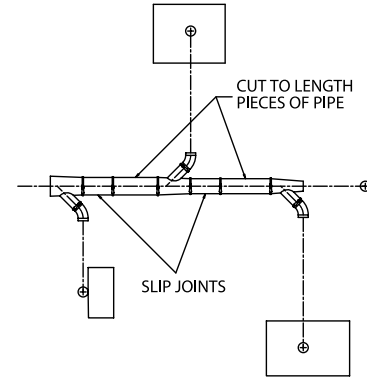

2

Connect the branches to ducting sections of the correct length and diameter. Adjustment to length on duct sections is achieved by using **LaserLock™** slip joint assembly instructions on page 29.

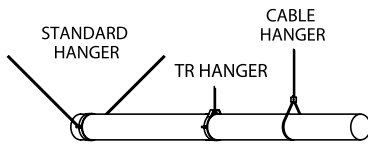

3

Carefully raise main or sub-main to required center line height above floor using preferred **LaserLock™** hanging material listed on page 24-25.

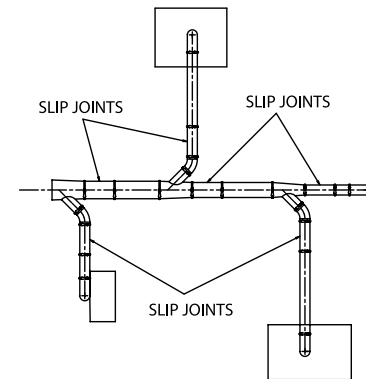

4

Extend branch arms to machines using correct length and diameter duct. Adjustment to length of duct sections is achieved by using **LaserLock™** slip joint assembly instructions on page 29. Fit another 90° elbow on end of each horizontal run.

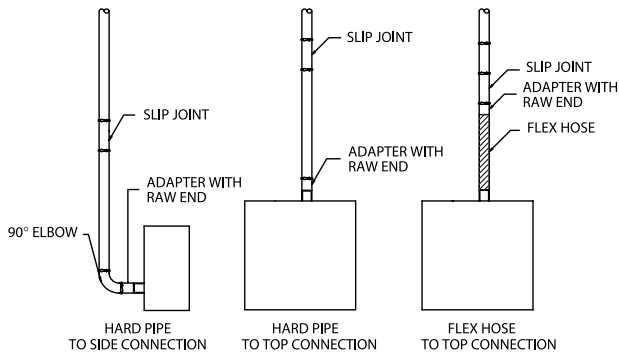

5

Install vertical risers from machines to horizontal runs using your preferred method of connection.

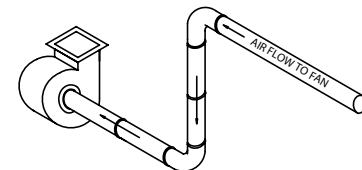

6

Connect main or sub-main to filter, fan or desired machinery with required standard or custom fitting manufactured by Duct Incorporated, or continue with next section of system.

SIZING A PIPE SYSTEM

SIZING BRANCHES



SIZING A PIPE SYSTEM

DUCT INCORPORATED offers assistance for those who need help designing a piping system. We can help determine the correct pipe size and configuration that will supply the flow you need. Please contact us at 1-877-BUY-DUCT for assistance.

USING THE CFM/FPM CHART. The following chart allows you to pick the correct pipe for the required CFM.

To prevent waste material from dropping out of the air stream, each type of material needs to be conveyed at different velocities. (See table on page 28.) For example, some waste materials flow well at 4500 feet per minute (FPM). Reviewing the chart, a 4" pipe will convey 395 CFM at 4500 FPM. This means that a 4" pick-up on a machine will use 395 CFM from the filtering system; or, if you know that a machine will require approximately 400 CFM to remove the waste, you should use a 4" pipe for that purpose.

Air Volume In Ducts In Cubic Feet Per Minute (CFM)

	2000	2500	3000	3500	4000	4500	5000	5500	6000	6500	7000
3	100	125	150	170	195	220	245	270	295	320	345
4	175	220	260	305	350	395	440	485	525	570	615
5	275	340	410	475	545	615	680	750	820	885	955
6	395	490	590	685	785	885	980	1080	1180	1275	1375
7	535	670	800	935	1070	1205	1335	1470	1605	1735	1870
8	700	875	1050	1220	1395	1570	1745	1920	2095	2270	2445
9	885	1105	1325	1545	1765	1990	2210	2430	2650	2870	3090
10	1090	1365	1635	1910	2180	2455	2725	3000	3270	3545	3820
12	1570	1965	2355	2750	3140	3535	3925	4320	4710	5105	5500
14	2140	2675	3205	3740	4275	4810	5345	5880	6415	6950	7485
16	2790	3490	4190	4885	5585	6285	6980	7680	8380	9075	9775
18	3535	4420	5300	6185	7070	7950	8835	9720	10600	11485	12370
20	4635	5455	6545	7635	8725	9815	10910	12000	13090	14180	15270
22	5280	6600	7920	9240	10560	11880	13200	14520	15840	17160	18480
24	6285	7855	9425	10995	12656	14135	15710	17280	18850	20420	21995
26	7370	9210	11055	12900	14740	16580	18420	20270	22110	23950	25800
28	8550	10685	12820	14960	17100	19230	21310	23500	25650	27780	29920
30	9800	12260	14700	17170	19625	22080	24530	26990	29440	31890	34350
32	11160	13950	16750	19541	22330	25120	27910	30700	33490	36380	39070

SIZING BRANCHES

Example: When working from your machines back toward the filter, you have a 5" drop that rises and joins with a 6" drop (see diagram below). How do you figure what size branch you'll need?

The 5" pipe carries 615 CFM at 4500 FPM (see chart above). The 6" pipe needs 885 CFM at the same velocity of 4500 FPM. Added together, there is a total of (615 + 885) 1500 CFM coming together.

Referring back to the chart under the 4500 CFM column, 1500 CFM is not listed, but is close to the 1570 CFM listed for an 8" pipe. This states that the 5" joined with the 6" requires an 8" pipe to carry the combined material at the correct velocity. The branch will need to be 8" on the downstream end reducing down to a 5" with a 6" branching off of it. This would be listed as an 8-5-6 branch.

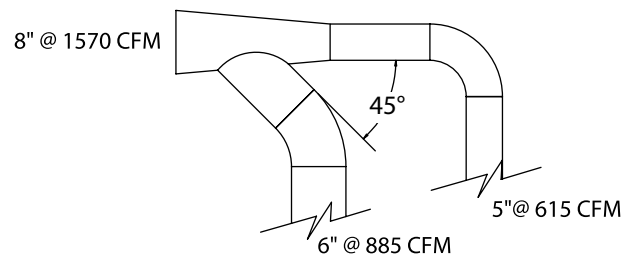
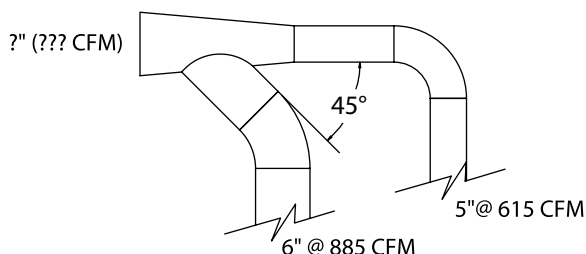

NAME:

PROJECT:

PHONE:

FAX:

COMPANY:

MATERIAL:

DATE:

PAGE:

GAGE: STANDARD UPGRADED TO _____

	3"	4"	5"	6"	7"	8"	9"	10"	11"	12"	13"	14"	15"	16"	17"	18"	20"	22"	24"	
Pipe 5' Length																				
Slip Joint Includes O-Ring																				
Elbows																				
90°																				
60°																				
45°																				
30°																				
Blast Gate																				
Floor Sweep																				
Machine Adapter Standard is ID																				
Flex Hose Adapter																				
Pipe Hanger STD TR Cable																				
Flex Hose Rubber or Steel																				
Flex Hose Clamp																				
Branch A																				
Double Branch B																				
Y Branch C																				
Reducers D																				
Other Fittings/ Transitions																				
Clamp																				



LASER WELDED CLAMP TOGETHER
DUCTING FOR ALL APPLICATIONS, FROM
LIGHT TO HEAVY GAGE DUCT OR
MODERATE TO SEVERE PROCESS CRITERIA.

SEND THE FAX FORM BELOW TO DUCT INCORPORATED FOR ALL THE INFORMATION YOU NEED.

FAX 336•768•0701

- RUSH! I HAVE A CURRENT PROJECT THAT REQUIRES LASERLOCK™ DUCT.
 PLEASE CALL ME FOR PROJECT.

NAME _____

TELEPHONE #(_____) _____

EMAIL _____ FAX #(_____) _____

COMPANY NAME _____

ADDRESS _____

CITY _____ STATE _____ ZIP _____

CURRENT NEED _____



STRATFORD INDUSTRIAL PARK • 2529 VICEROY DRIVE
WINSTON-SALEM, NC 27103-6713

P TOLL FREE 877-BUY-DUCT (289-3828) **D** 336-768-0700 **F** 336-768-0701
E SALES@DUCTINCORPORATED.COM **W** WWW.DUCTINCORPORATED.COM

877•BUY•DUCT